

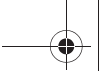

Introduction of the smart fortwo Model series 451

Introduction into Service Manual





Introduction of the smart fortwo Model Series 451

Introduction into Service Manual



smart USA

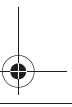
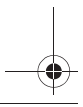

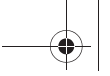

Copyright

© smart USA, 2007

All rights reserved. Reproduction by any means, electronic or mechanical, including photocopying, recording, or by any information storage and retrieval system or translation in whole or part is not permitted without written authorization from the publisher.

Published by smart USA, 2007

Printed in U.S.A.

www.smartusa.com

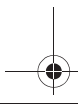
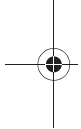

Preface	7
Complete vehicle	
Overview	8
Technical data	10
Maintenance	13
Safety concept	17
Electrical system	
On-board electrical system/power supply	20
Complete networking	22
Wiring harnesses	24
Diagnosis	26
SAM control unit	28
Engine M132	
Engine description	30
Performance graph	30
Engine data	32
Valve assembly	33
Valve timing	34
Gasoline injection and ignition system	35
Belt drive	38
Cooling system	39
Engine mount	41

Content

Fuel system

Fuel supply 42

Exhaust system

Overview 45

Secondary air injection 46

Automated manual transmission

Transmission description 47

Transmission data 48

Shift mechanism 49

Synchronization 54

Transmission control 55

Park pawl 61

Clutch 62

Chassis

Front axle 64

Rear axle 65

Rear module 66

Tire pressure monitor 67

Brakes 69

Steering 75

Content

Body	
Interior	82
Doors/flaps	86
Roof systems	90
Central locking	96
Anti-theft alarm system (ATA [EDW])	99
Exterior lights	101
Audio system	102
Climate control	104
Customized Bodypanel System (CBS)	106
Seats	108
Supplemental restraint system	109
Body	113

Accessories	
smart accessories	116
Index	120

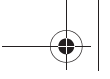

Content

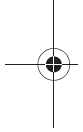

Preface

Dear reader,

This Introduction into Service Manual presents the new smart fortwo in model series 451.

The purpose of this manual is to inform you of the technical features of this new vehicle. This brochure is intended to provide information for people employed in service, maintenance and repair as well as for aftersales staff.

In terms of the contents, the emphasis in this Introduction into Service manual is on presenting the major assemblies and systems.

This Introduction into Service manual is not intended as an aid for repairs or for the diagnosis of technical problems. For such needs, more extensive information is available in the Workshop Information System (WIS) and in the Diagnosis Assistance System (DAS).

WIS is updated monthly. Therefore, the information available there reflects the latest technical status.

This Introduction into Service Manual presents initial information relating to the new smart fortwo in model series 451 and, as such, is not stored in WIS. The contents of this brochure are not updated. No provision is made for supplements.

We will publicize modifications and new features in the relevant WIS documents. The information presented in this Introduction into Service Manual may therefore differ from the more up-to-date information found in WIS.

All information relating to technical data, equipment and options is valid as of the copy deadline in September 2007 and may therefore differ from the current production configuration.

smart USA aftersales

Overview



smart fortwo coupé

P00.10-4192-00

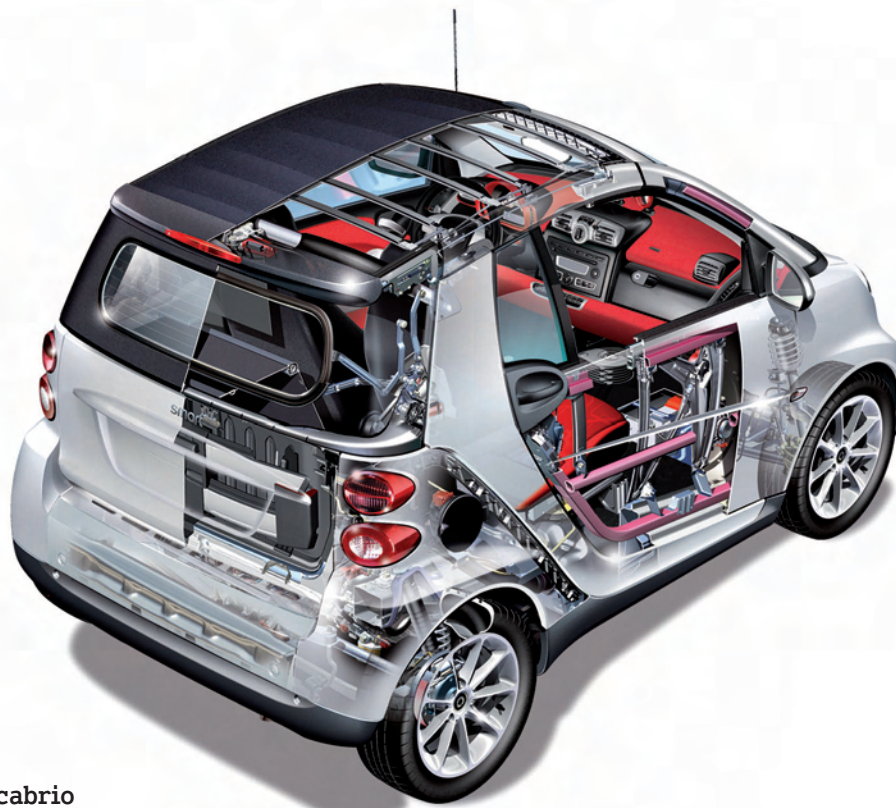

smart fortwo cabrio

P00.10-4198-00

Vehicle concept

Externally, the smart fortwo is immediately distinguishable by its compactness with the tridion safety cell and its two-tone design. The smart fortwo is available in a variety of colors. The tridion safety cell in black or silver can be combined with six different basic colors.

The model series can be ordered as the smart fortwo coupé or the smart fortwo cabrio.

Despite its compact appearance, the smart fortwo provides the occupants with a generous amount of legroom and sufficient trunk capacity.

The interior compartment has a classic design. The instrument panel was designed with straight lines and the colors have been kept refined. Repeated aluminum accent trim on the air vents and the inside door handles gives the interior design a harmonic yet modern aspect.

Vehicle characteristics

- **Overall vehicle exterior**

External dimensions to suitably accommodate the occupants and provide sufficient the trunk capacity.

Plastic panoramic sunroof or full roof on the smart fortwo coupé.

Tritop soft top on the smart fortwo cabrio.

- **Overall vehicle interior**

Numerous color and pattern variants in the interior.

Ergonomic instrument cluster in the instrument panel.

Clearly arranged and user-friendly center console.

Rear-end door with integral stowage compartment for the smart fortwo coupé or tight-fitting stowage areas without retaining straps for the roof side supports in the smart fortwo cabrio.

- **Engine/injection system**

3-cylinder gasoline engine with 52 kW.

Fuel injection system with Bosch Multi-Point-Injection.

- **Transmission**

5-speed automated manual transmission AMT 2 (2nd generation).

- **Suspension**

MacPherson front suspension with torsion stabilizer bars.

DeDion rear axle.

- **Brake**

Hydraulic 2-circuit brake system with ESP and TT (front/rear) split, version 8.1 from Bosch.

- **Steering**

Equipped with rack-and-pinion steering as standard.

Electromechanical power steering with active steering centering and adaptation of the steering forces available as special equipment.

- **Maintenance**

Maintenance concept: Maintenance service only every two years, with only the Oil Service Plus once a year in between.

Service flap at front for easy access to the maintenance points.

- **Safety**

Restraint system with airbags and emergency tensioning retractors.

Bodyshell made of high-strength steels.

Door reinforcements made of high-strength steels.

Full-length knee guard for driver and passenger.

Technical data

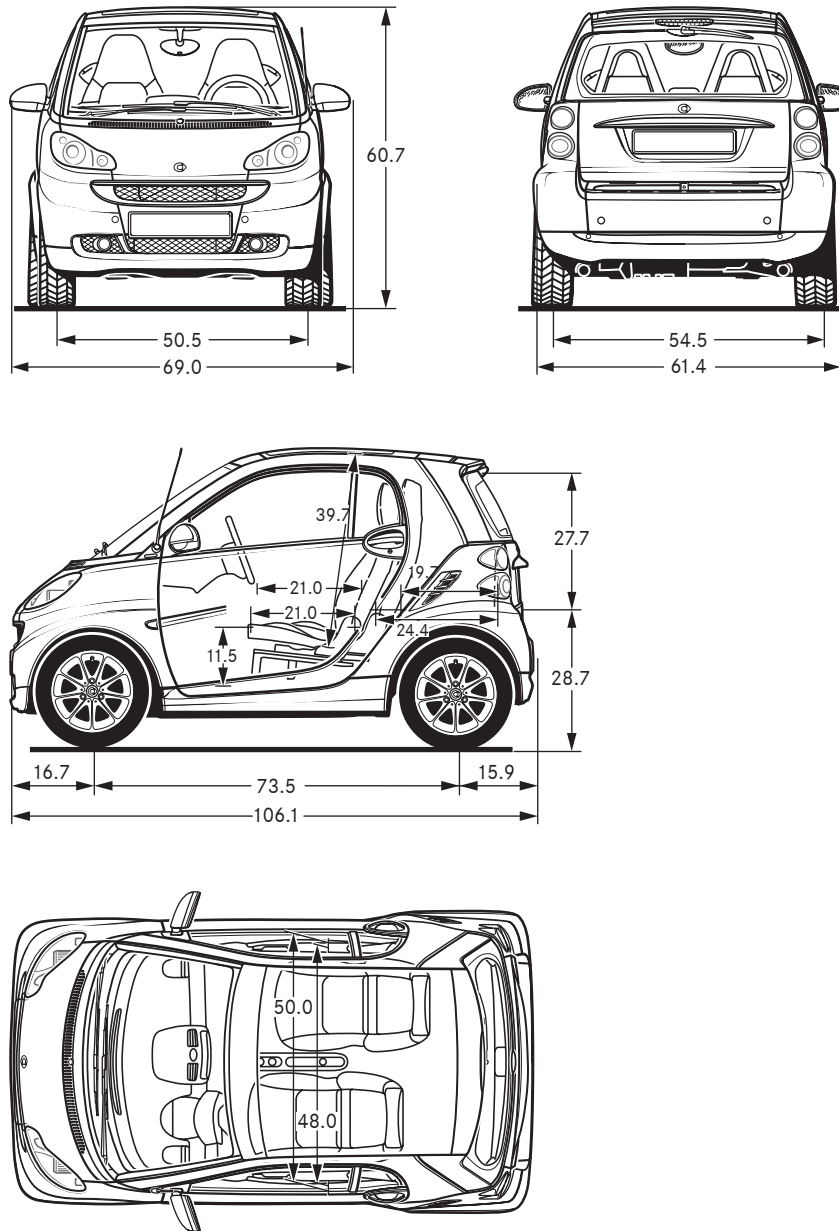

Dimensions - smart fortwo coupé

P00.10-4259-00

Dimensions	Unit	smart fortwo coupé (model 451)
Vehicle length	in (mm)	106.1 (2695)
Vehicle width	in (mm)	61.4 (1559)
Vehicle height	in (mm)	60.7 (1542)
Wheelbase	in (mm)	73.5 (1867)
Front track width	in (mm)	50.5 (1283)
Rear track width	in (mm)	54.5 (1385)

Technical data

Complete vehicle

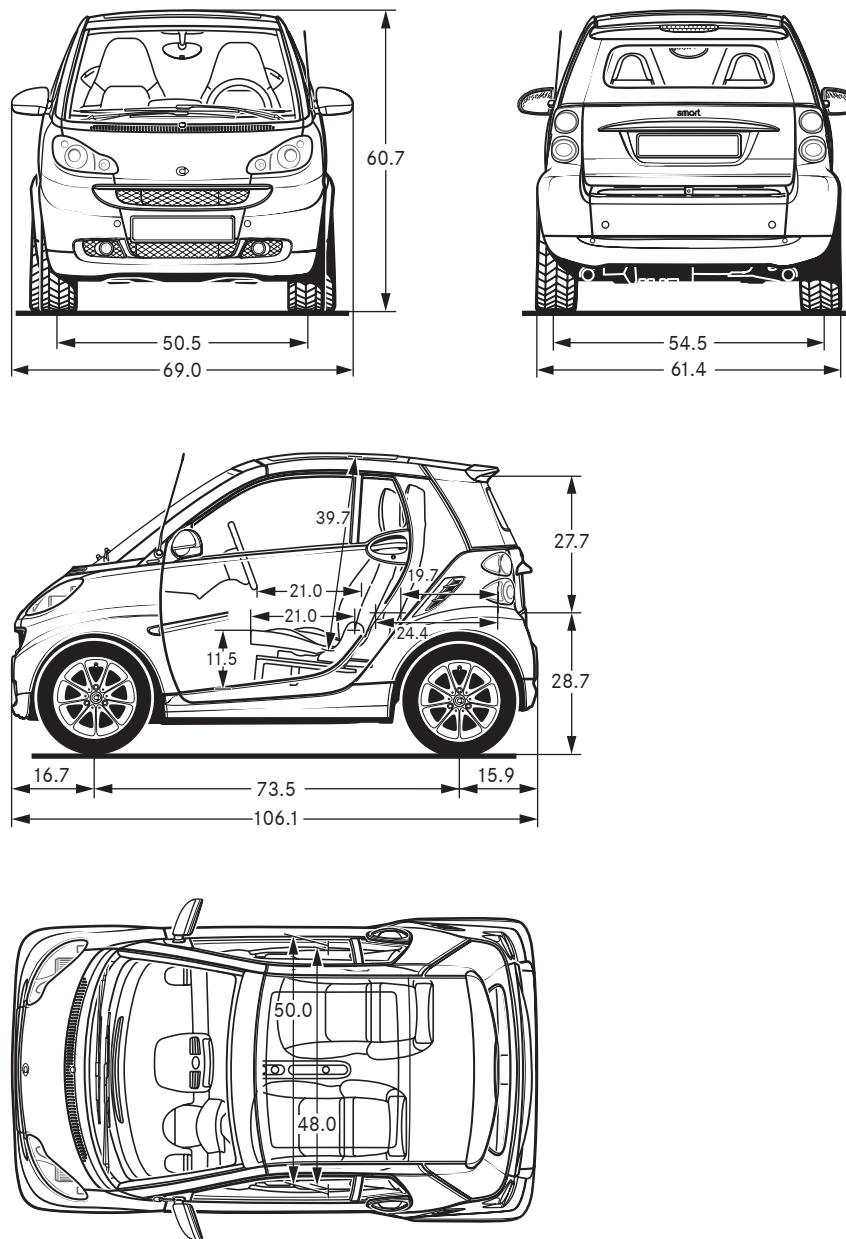

P00.10-4260-00

Dimensions - smart fortwo cabrio

Dimensions	Unit	smart fortwo cabrio (model 451)
Vehicle length	in (mm)	106.1 (2695)
Vehicle width	in (mm)	61.3 (1559)
Vehicle height	in (mm)	60.7 (1542)
Wheelbase	in (mm)	73.5 (1867)
Front track width	in (mm)	50.5 (1283)
Rear track width	in (mm)	54.5 (1385)



Technical data

Models and major assemblies

smart fortwo	Model	Engine	Transmission
smart fortwo coupé	451.331	132.910 (52 kW)	717.482
smart fortwo cabrio	451.431		

Loads, weights and other data

	Unit	smart fortwo coupé	smart fortwo cabrio
Powerplant	kW	52	52
Permissible front axle load	lb (kg)	969 (440)	
Permissible rear axle load	lb (kg)	1458 (660)	
Curb weight as per DIN	lb (kg)	1652 (820)	1740 (840)
Permissible gross vehicle weight	lb (kg)	2247 (1050)	2247 (1050)
Payload	lb (kg)	595 (230)	507 (210)
of which max. in luggage compartment	lb (kg)	110 (50)	
Max. seating capacity		2	
Luggage compartment volume			
up to belt line	in ³ (l)	7.8 (220)	
up to roof	in ³ (l)	12 (340)	
Turning circle	yd (m)	9.57 (8.75)	
Tank capacity/including reserve	US gal (l)	8.72/1.32 33/5	



Maintenance

Complete vehicle

Maintenance concept

Consistent product development has enabled a future-oriented servicing concept to be implemented in model series 451.

The servicing concept of the smart fortwo has allowed the service intervals to be extended significantly, as shown below.

Maintenance intervals

smart fortwo	kW	Interval
Gasoline engine	52	Every 2 years or 20,000 miles*

* depending on first occurrence

Oil Service Plus

In combustion engines with a high engine output per unit of displacement, the engine oil is subjected to extreme loads. With 3.7 US qt (3.5 liters), the smart fortwo has a relatively small quantity of engine oil, meaning that it has to be replaced at regular time/mileage intervals.

To help optimize operating costs, the "Oil Service Plus" has been introduced, which is due every 10 000 miles or once per year. It comprises merely an engine oil change and inspection of the safety-relevant components and functions.

This servicing concept has benefits for both the workshops and the customers:

- Customers have lower vehicle operating costs due to the reduced maintenance costs as a whole. This improves customer satisfaction.
- The workshops improve their competitiveness in the servicing business especially. Longer-lasting customer loyalty and better chances of follow-up business are possible with this concept.

Maintenance

Maintenance interval display (WIA)

The maintenance interval display is located in the multifunction display of the instrument cluster.

The maintenance intervals are indicated by the lighting of one or two wrench symbols.

In addition, approximately one month in advance of a scheduled service date the multifunction display shows the remaining time (in days) until it is due. After engine start the range (in miles) is displayed for about ten seconds.

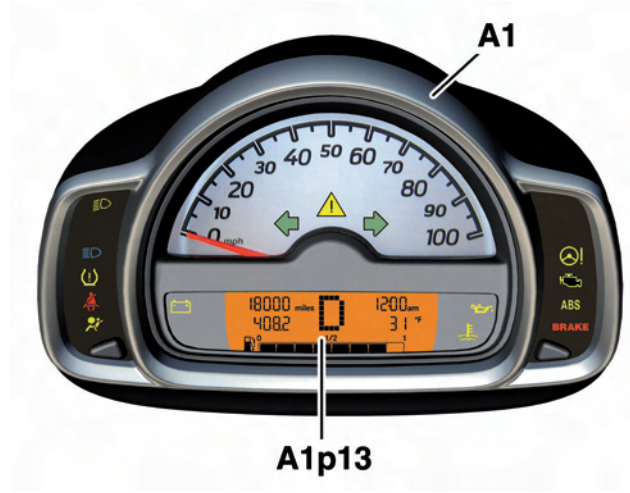

P54.32-5676-00

Instrument cluster

- A1 Instrument cluster
- A1p13 Multifunction display

i Note

When the Oil Service Plus or a maintenance service has been performed, the maintenance interval display can be reset to the starting distance on the instrument cluster itself or via STAR DIAGNOSIS.
(See WIS for a detailed description.)

Meaning of wrench symbols:

- 1 wrench means **Oil Service Plus**
- 2 wrenches mean **maintenance service**



P54.32-5677-00

Multifunction display with maintenance interval display

Maintenance

Service flap

The smart fortwo is equipped with a detachable service flap which allows convenient access to all maintenance points in the front section. Customer-relevant maintenance items can be performed by the customer accordingly.

To remove the service flap, levers located in the air grille on each side must be operated to unlock the service flap. The service flap can then be removed and suspended by two brackets on the front of the vehicle. A check strap prevents the service flap from falling down.

Maintenance points at front end

The most important maintenance points at the front of the car are:

- Brake fluid reservoir
- Windshield washer fluid reservoir
- Coolant expansion reservoir
- Lamp units for bulb replacement

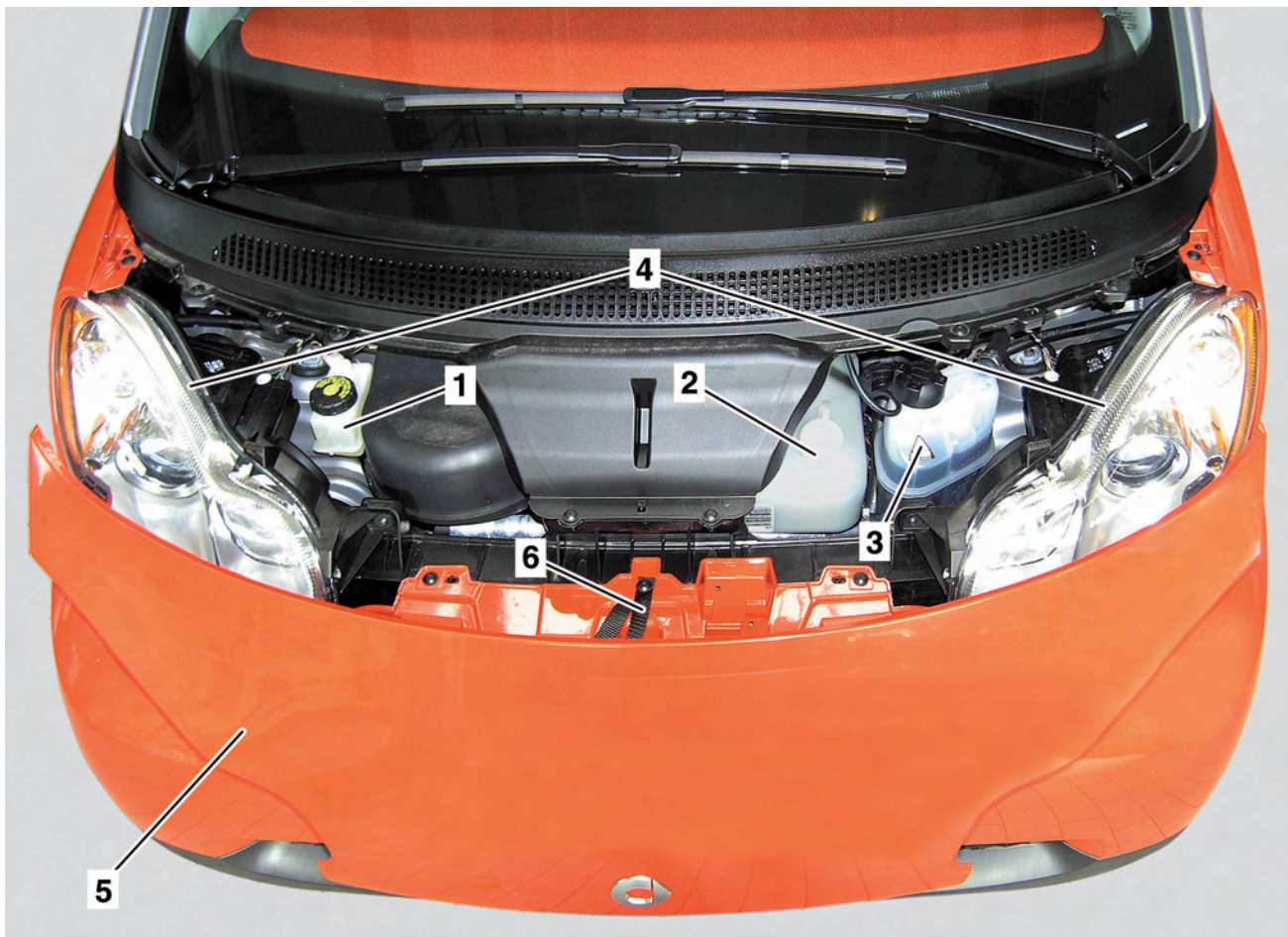

P00.20-2629-00

Maintenance points at front end

- | | |
|-------------------------------------|----------------------------------|
| 1 Brake fluid reservoir | 4 Lamp unit for bulb replacement |
| 2 Windshield washer fluid reservoir | 5 Service flap |
| 3 Coolant expansion reservoir | 6 Check strap |

Maintenance

Maintenance points in engine compartment

The maintenance points in the engine compartment can be accessed once the engine compartment cover in the luggage compartment floor has been removed.

The most important maintenance points in the engine compartment are:

- Oil filler neck
- Oil dipstick
- Air filter housing
- Spark plugs

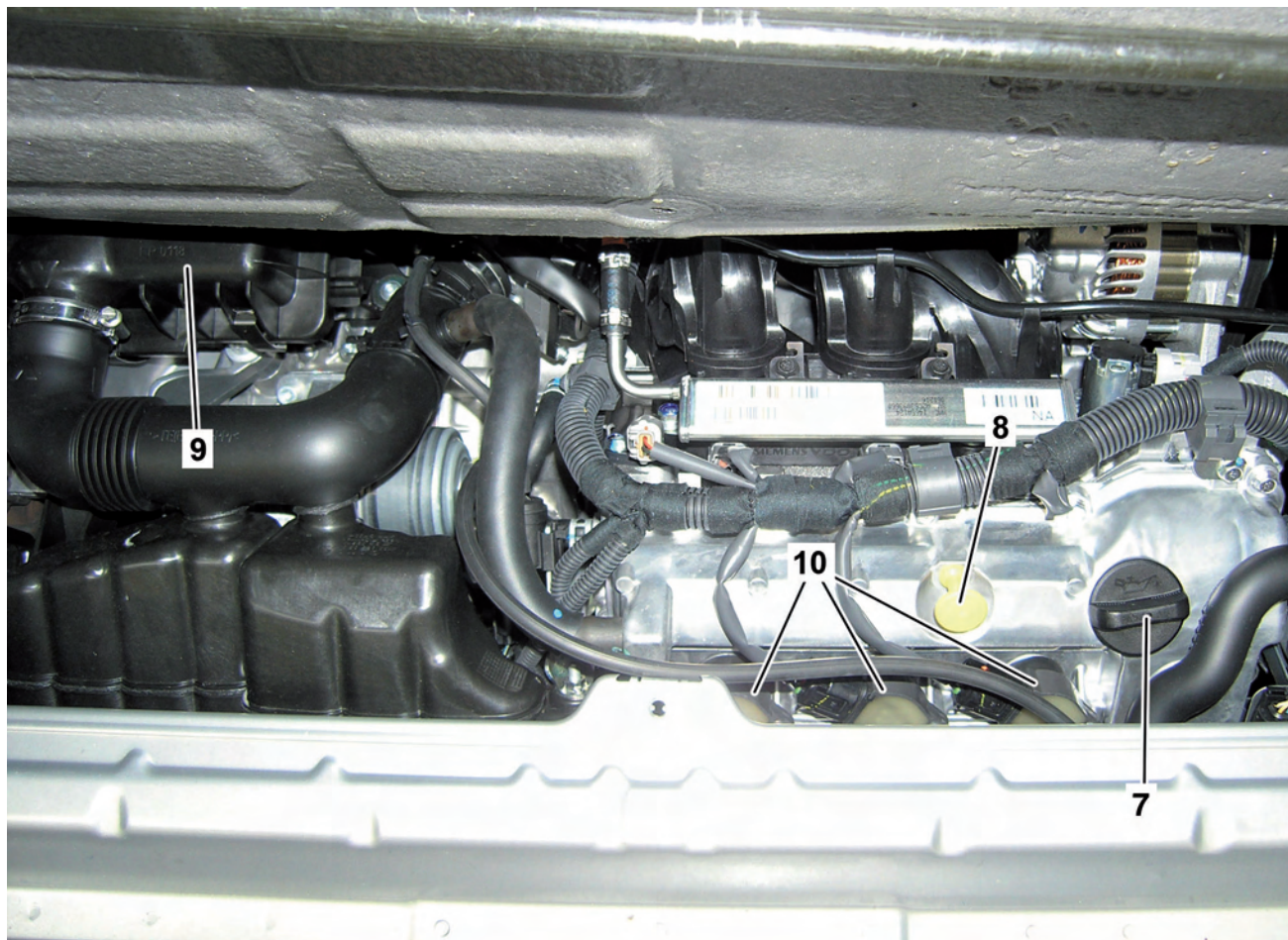

P00.20-2630-00

Maintenance points in engine compartment

- | | |
|-------------------|---------------------------------|
| 7 Oil filler neck | 9 Air filter housing |
| 8 Oil dipstick | 10 Ignition coils (spark plugs) |

Safety concept

Complete vehicle

In the smart fortwo, high levels of active safety are provided by both tried-and-tested and newly developed systems and components.

Active safety

Active safety includes measures and equipment that help to prevent detected dangers from occurring in the first place, or that warn the driver of dangers in advance, or that assist him in critical driving situations:

A distinction is drawn between the following safety aspects:

- Driving safety
- Stress-reducing safety
- Perceptual safety
- Operating safety

The components responsible for maintaining **driving safety** include:

- Electromechanical power steering (SA)
- 5-speed automated manual transmission
- Vehicle dynamics systems:
 - ABS (antilock brake system)
 - ASR (acceleration skid control)
 - ESP (electronic stability program)

High levels of **stress-reducing safety** are due to:

- Comfortable seats with integral head restraints
- Temperature-regulated air conditioning

High levels of **perceptual safety** are assured by the following components:

- Auto on/off headlamps (SA)
- Center high-mounted brake lamp in the roof spoiler

Operating safety is provided by:

- Ergonomically designed driver area
- Clearly arranged and easily reachable controls

Safety concept

Passive safety

The goal of a vehicle's passive safety is to minimize as much as possible the effects of an accident on the people involved. Some of the most important aspects of this are the preservation of the survival space (rigid passenger cell), high energy dissipation in the event of an accident thanks to exploitable crumple zones at the front and rear, and energy-absorbing restraint systems in the interior.

The passive safety concept includes:

- tridion safety cell consisting of 50% high-strength steel
- Crash management system (CMS) at the front and rear, which absorbs energy at low vehicle speeds and prevents expensive bodyshell damage
- Front end with no major assemblies, for effective exploitation of the short overhang as a crumple zone
- Inclusion of the wheels and axles/frame-type integral support in the crumple zone and for force application
- Front and rear structures with several impact planes and large cross sections to transfer and disperse the crash energy that is generated
- Long forward displacement area for the driver and passenger with restraint systems adapted to compensate for the "short" crumple zone
- Sturdy steel seat structures for effective protection against shifting cargo and for specific deformation in rear-end collisions
- Side doors made of solid steel frame profiles including side impact protection
- Safe positioning of the fuel tank in the underfloor area between the axles
- Deformable steering column to dissipate energy, prevent intrusion and lengthen the forward displacement distance in a frontal collision
- Full interior lining to reduce head injuries

The occupant restraint systems comprise:

- 2-stage driver airbag in steering wheel
- 2-stage top-mounted passenger airbag with deployment opening on the top surface of the instrument panel
- Head/thoraxbags in the backrests
- Three-point seat belts with emergency tensioning retractors, belt force limiters and belt guides on the backrests
- Seat belt reminders for driver and passenger
- Belt tension sensor on passenger side
- Passenger seat with Weight Sensing System (WSS) with automatic passenger airbag deactivation for the corresponding weight classes and airbag OFF indicator lamp
- Full-length knee guard
- Two frontal acceleration sensors on front crossmember
- Two satellite sensors on inner side wall in area of left and right B-pillar
- Restraint systems control unit



P91.60-3663-00

- 1 Driver airbag
- 2 Passenger airbag
- 3 Head/thoraxbag

Safety concept

Protective measures for pedestrians and cyclists comprise:

- Single-piece front end module
- Main headlamps with predetermined fracture point
- Concealed and retracting windshield wiper shafts
- Energy-absorbing covering on the center piece in front of the windshield
- Large, soft plastic surfaces at the front

The extended range of functions following an accident includes:

- Automatic engine off feature
- Interruption of the fuel supply
- Unlocking of the doors
- Activation of the hazard warning system

Complete vehicle

On-board electrical system/power supply

General

The on-board electrical system ensures that the power supply to all the electrical consumers and components in the vehicle is appropriate for the requirements and the situation.

The on-board electrical system consists of the following main components:

- Starter
- Battery
- Alternator
- ME-SFI [ME] control unit
- Instrument cluster

Starter

The starter has an output of 0.95 kW and supplies the torque necessary to start the engine. It takes the necessary energy from the adequately charged battery.

Battery

The battery (42 Ah) supplies the consumers when the engine is off, the starter while the engine is being started, and the on-board electrical system when the alternator is unable to provide the required consumer current.

The battery is located in the passenger footwell under the carpeting.

There are three fuses located in the area of the battery:

F36 Secondary air injection pump fuse

F58 Starter/alternator fuse

F91 SAM prefuse

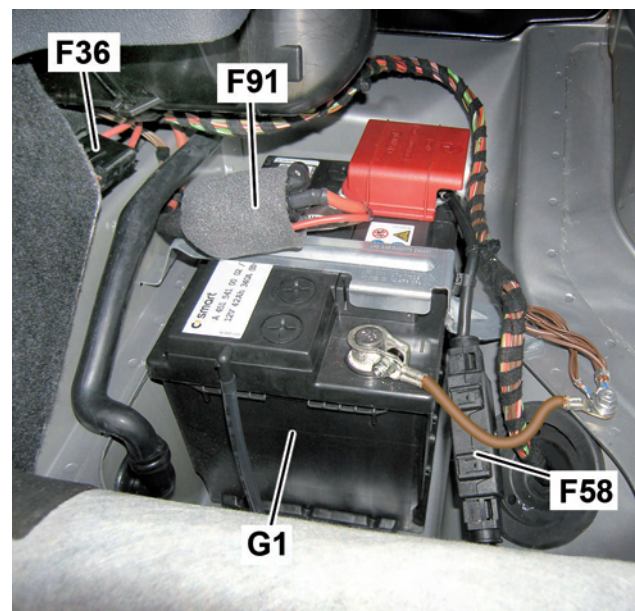

P54.10-2890-00

<i>G1</i>	<i>Battery</i>
<i>F36</i>	<i>Secondary air injection pump fuse</i>
<i>F58</i>	<i>Starter/alternator fuse</i>
<i>F91</i>	<i>SAM prefuse</i>

On-board electrical system/power supply

Alternator

The alternator supplies the electrical consumers while the engine is running and recharges the battery so that a subsequent engine start is possible. The alternator is equipped with an overvoltage protection function that limits the on-board power supply voltage in the event of a defect in the governor. The alternator is monitored by the ME-SFI [ME] control unit.

The alternator is pre-excited via a direct line. The alternator load is reported back to the ME-SFI [ME] control unit over a separate line and monitored.

Instrument cluster

The on-board power supply voltage is monitored by the engine control. If the voltage is $< 11.5\text{ V}$ for a period of over 3 min, a signal is sent over CAN to the instrument cluster and the alternator charge monitoring and warning lamp (A1e5) lights up.

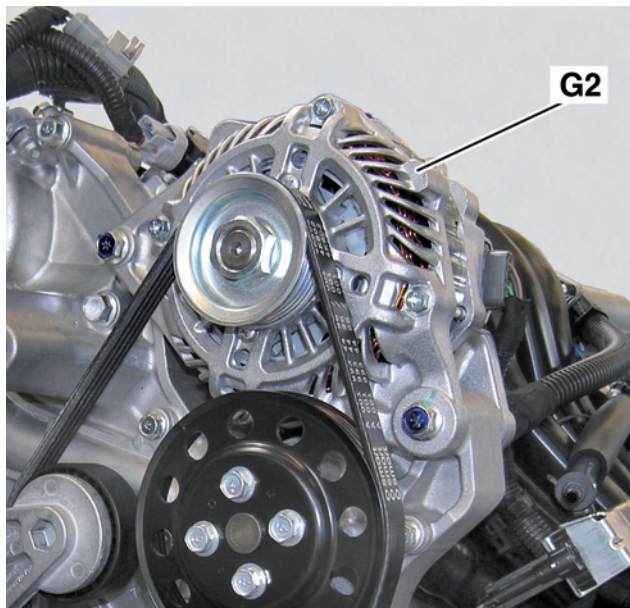

G2 Alternator

P54.10-2891-00

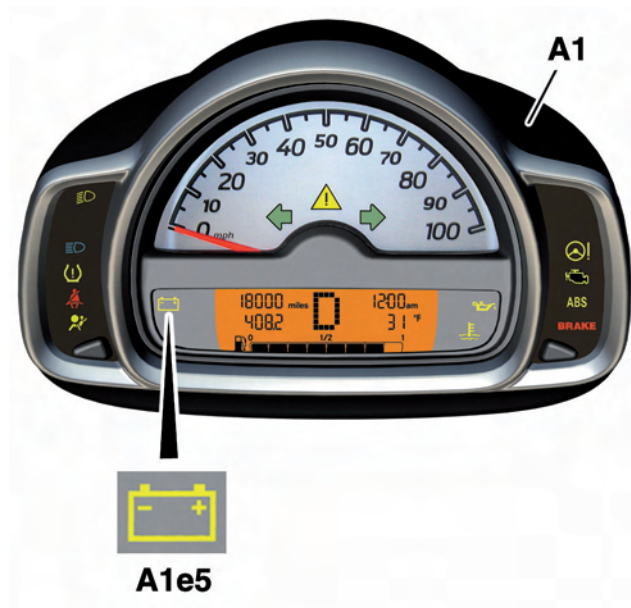

A1 Instrument cluster

A1e5 Alternator charge monitoring and warning lamp

P54.32-5684-00

Complete networking

Overall network - location of components

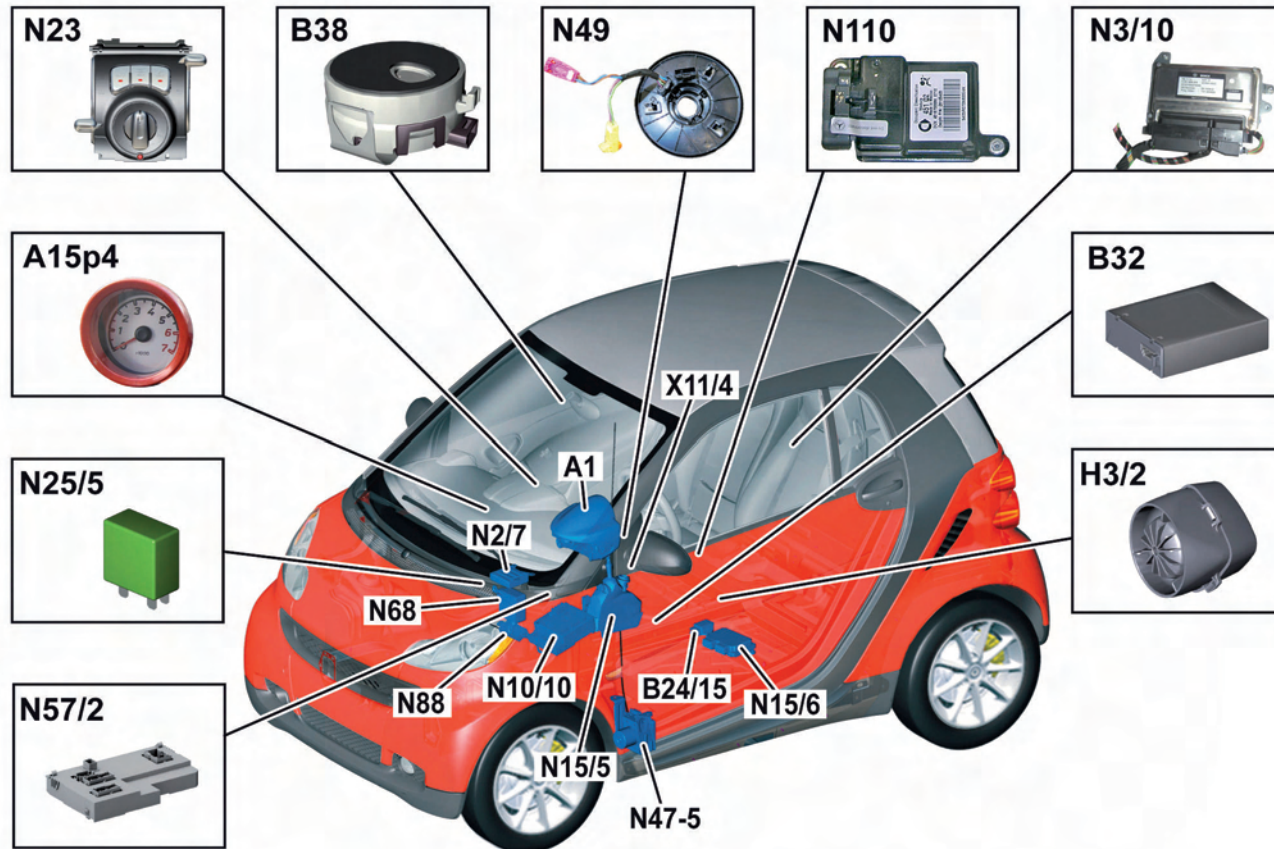

P00.19-4338-00

Overall network - full equipment

<p><i>A1</i> Instrument cluster on the left side of the instrument panel</p> <p><i>A15p4</i> Tachometer (with code (V31) Cockpit clock and tachometer package) in the center of the instrument panel</p> <p><i>B24/15</i> Yaw rate, lateral and longitudinal acceleration sensor under the floor covering near the driver seat</p> <p><i>B32</i> ATA [EDW] microwave sensor (with code (V01) Anti-theft alarm system (FFO)) under the center console near the handbrake lever</p>	<p><i>B38</i> Rain sensor/light sensor (with code (V54) Rain/light sensor) in the middle of the windshield near the inside rearview mirror</p> <p><i>H3/2</i> Alarm siren with inclination sensor (with code (V01) Anti-theft alarm system (FFO)) on the right in front of the fuel tank</p> <p><i>N2/7</i> Restraint systems control unit in the center under the instrument panel</p> <p><i>N3/10</i> ME-SFI [ME] control unit behind the right side paneling in the rear</p> <p><i>N10/10</i> SAM control unit on the left under the instrument panel</p> <p><i>N15/5</i> Electronic selector lever module control unit</p>
---	--

(Legend continued on the next page)

Complete networking

Overall network - CAN bus/LIN bus

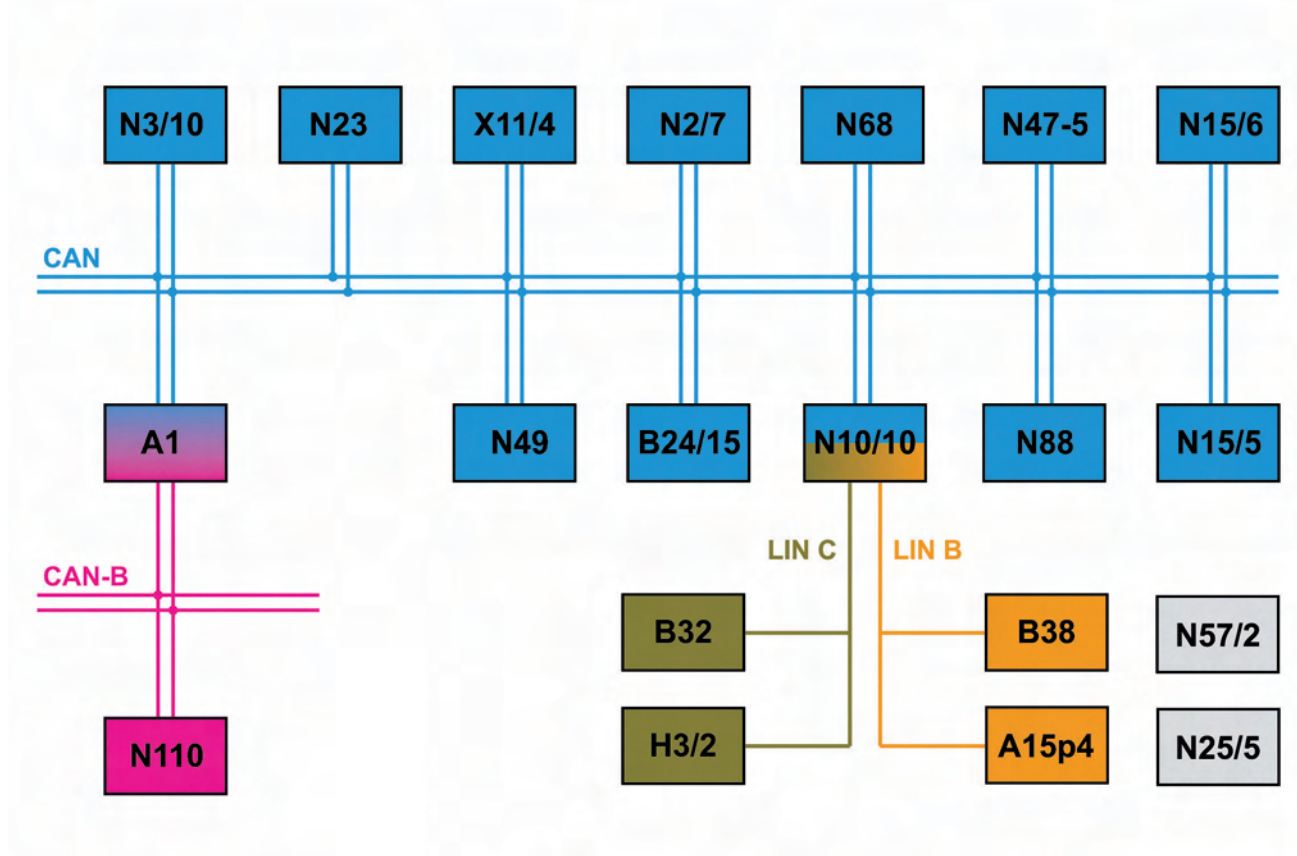

P00.19-4339-00

Block diagram - Full equipment

- | | |
|--|--|
| <p><i>N15/6</i> Automated manual transmission control unit under the floor covering near the driver seat</p> <p><i>N23</i> Heater/AC operating unit (with code (I01) Air conditioning Plus and code (V30) Outside temperature sensor (FFO)) in the center of the instrument panel</p> <p><i>N25/5</i> Front HS [SIH] control unit (with code (S17) Seat heaters (FFO)) in the center under the instrument panel</p> <p><i>N47-5</i> ESP control unit on ESP hydraulic unit</p> <p><i>N49</i> Steering angle sensor in steering wheel</p> | <p><i>N57/2</i> Power window convenience feature control unit (with code (V43) Power windows) on the left under the instrument panel</p> <p><i>N68</i> Power steering control unit (with code (V26) Power steering, EPS (FFO)) in interior compartment on left of firewall</p> <p><i>N88</i> TPM [RDK] control unit on left below instrument panel</p> <p><i>N110</i> Weight Sensing System (WSS) control unit on underside of passenger seat</p> <p><i>X11/4</i> Data link connector on the bottom of the instrument panel on the driver side</p> |
|--|--|
-
- | | |
|--------------|--|
| <i>CAN</i> | Controller Area Network bus (data bus/CAN bus) |
| <i>CAN-B</i> | Controller Area Network bus class B (interior compartment) |
| <i>LIN B</i> | Interior Local Interconnect Network 1 |
| <i>LIN C</i> | Interior Local Interconnect Network 2 |

Wiring harnesses

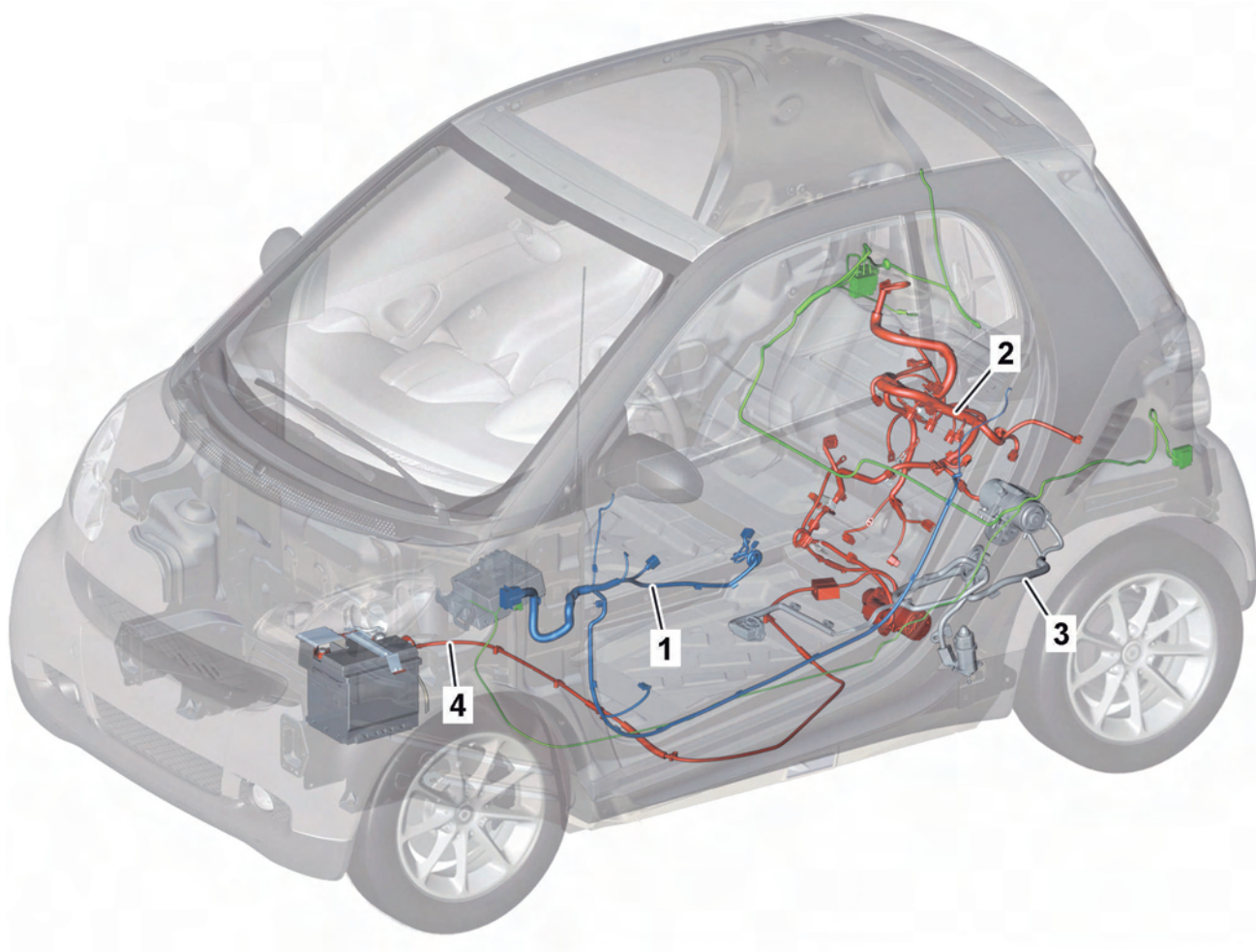

Wiring harness groups

P54.18-4507-00

The wiring harness is divided into the following groups:

- 1 Main wiring harness
- 2 Engine wiring harness
- 3 Transmission wiring harness
- 4 Battery wiring harness

Not illustrated:

- Door wiring harness
- Soft top wiring harness (in smart fortwo cabrio)
- Rear-end door wiring harness

Wiring harnesses

General

The wiring harness variants result from the basic standard equipment, the special equipment items and the national versions.

Repair capability

A basic wiring harness repair kit in a case is available for repairing individual lines, wiring harnesses and connectors **without sealed** plugs. All the above repairs can be carried out using this kit.

It is also possible to expand the kit with a supplemental repair set to allow wiring harnesses **with sealed** plugs to be repaired.

i Note

W000 589 13 99 00

Basic wiring harness repair kit.
Tools for repairing individual lines, wiring harnesses and connectors in combination with the wiring harness repair kit supplement for passenger cars (W220 589 04 99 00).

W220 589 04 99 00

Wiring harness repair kit supplement for passenger cars
Tools for repairing individual lines, wiring harnesses and connectors in combination with the basic wiring harness repair kit (W000 589 13 99 00).



P54.18-4140-00

Wiring harness repair kit

Diagnosis

General

The network architecture in model 451 allows external access to individual control units in the CAN bus system.

Data link connector

The CAN bus is accessed by means of a diagnostic tester that is connected to the vehicle via the data link connector. The data link connector is linked directly to the CAN bus and can therefore access all the control units that have diagnostic or programming capability. The data link connector is located in the vehicle interior on the underside of the instrument panel on the driver side.

Diagnostic tester

By connecting the diagnostic tester, the vehicle with all its equipment variants can be precisely identified. This enables accurate fault evaluation and rectification and the analysis of vehicle-specific values and parameters.

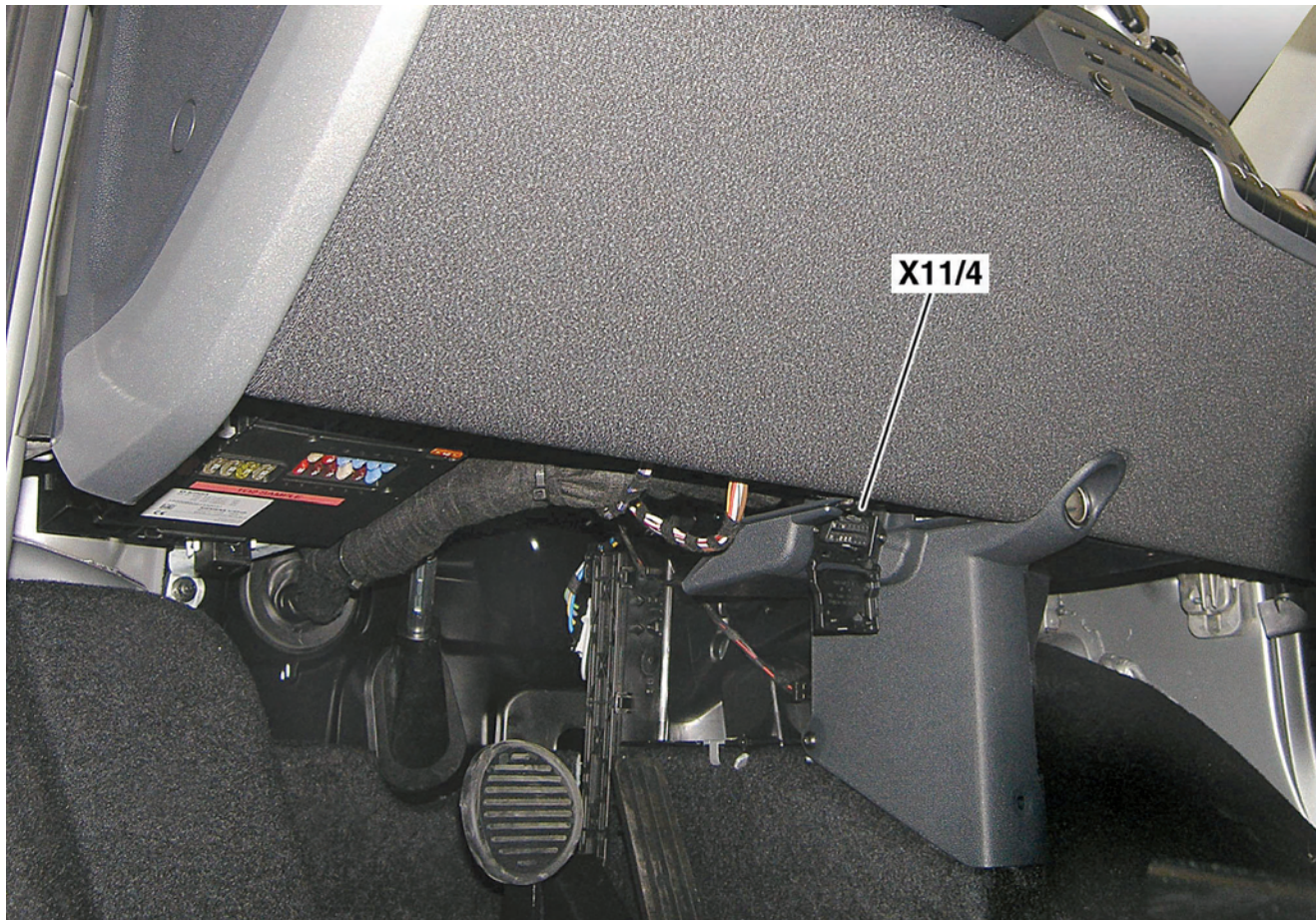

Location of data link connector (X11/4)

P54.22-2048-00

Diagnosis capability

The following control units have diagnosis capability:

- Instrument cluster
- Restraint systems control unit
- WSS control unit
- ME-SFI [ME] control unit
- SAM control unit
- Automated manual transmission control unit
- Heater/AC operating unit
- ESP control unit
- Steering assist control unit
- TPM [RDK] control unit
- Electronic selector lever module control unit

Fault memory

Each of the control units listed above has a fault memory that provides information about the associated systems. The stored faults are displayed by the diagnostic tester and must be rectified. When all the faults have been eliminated, the fault memory must be erased and read out again. There should be no fault entries left afterwards.

Maintenance intervals

The diagnostic tester is used to reset the maintenance interval in the instrument cluster following an Oil Service Plus or a maintenance service.

Programming control units

The following control units can be programmed:

- ME-SFI [ME] control unit
- SAM control unit
- Automated manual transmission control unit
- ESP control unit

TAN generator

For the following applications a TAN (transaction number) must be generated:

- Retrofitting the steering wheel gearshift (SAL)
- Replacing the ME-SFI [ME] control unit
- Replacing the SAM control unit
- Teach-in of transmitter keys (after loss or detection of additional transmitter keys)

Note

Up to six transmitter keys in total can be taught in at the same time.

SCN (Software Calibration Number) coding

The following control units can be coded via the SCN coding process:

- ME-SFI [ME] control unit^{*)}
- SAM control unit
- ESP control unit
- Automated manual transmission control unit^{*)}
- Restraint systems control unit
- Instrument cluster

^{*)} The control unit is relevant to exhaust emissions, i.e. the SCN is written in the control unit and can be interrogated. For the other control units a virtual SCN is generated during the coding process, but this is not written to the control unit.

SAM control unit

Almost all of the fuses in model 451 are accommodated on the SAM control unit. Slots 1–31 are located on the front of the SAM control unit; slots 32–35 are located on the rear.

The following fuses are not accommodated on the SAM control unit:

- Secondary air injection pump fuse (F36)
- Starter/alternator fuse (F58)
- SAM prefuse (F91)

The SAM control unit is installed in the vehicle interior on the left side near the A-pillar under the instrument panel.

The SAM control unit is linked with the CAN in order to exchange data. It communicates with the following components:

- Instrument cluster
- ESP control unit
- Restraint systems control unit
- ME-SFI [ME] control unit
- Heater/AC operating unit
- Steering assist control unit
- TPM [RDK] control unit
- Weight Sensing System (WSS) control unit
- Yaw rate, lateral and longitudinal acceleration sensor
- Steering angle sensor
- Data link connector

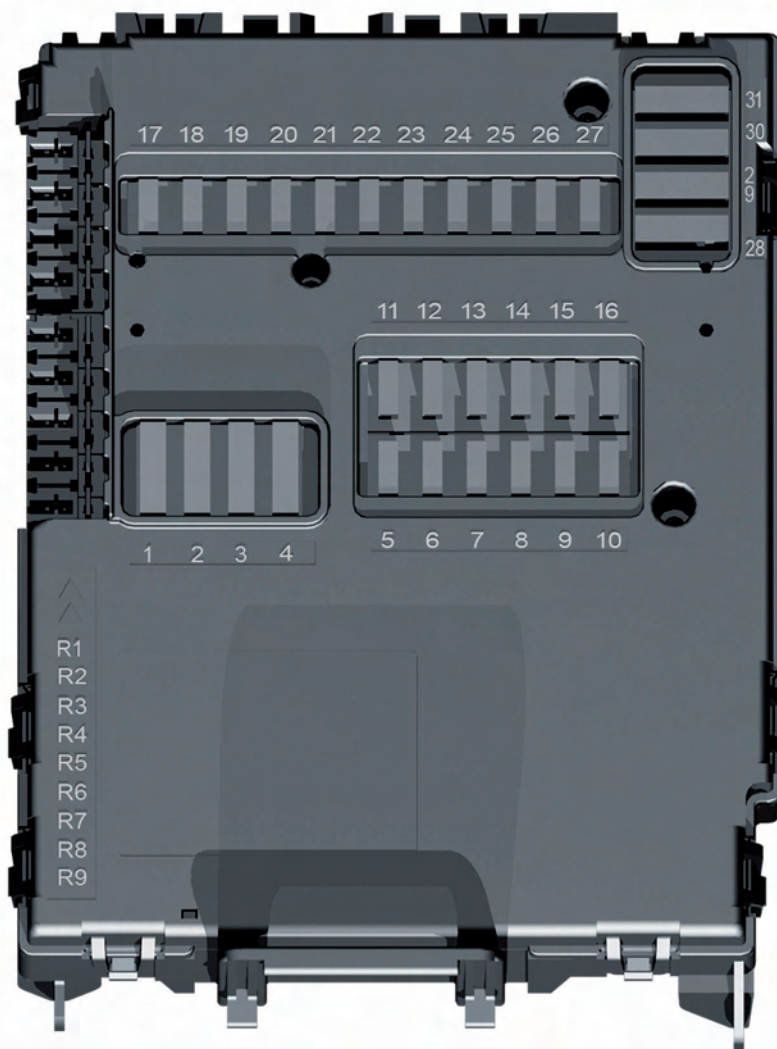

SAM control unit (front)

P54.21-2702-00

SAM control unit

The SAM control unit also communicates over:

- LIN B with the tachometer and the rain sensor/light sensor
- LIN C with the ATA [EDW] microwave sensor and the alarm siren with inclination sensor.

The fuse and relay box is integrated in the SAM control unit.

The following relays are not accommodated on the SAM control unit:

- Left turn signal/brake light relay (K52/11)
- Right turn signal/brake light relay (K52/12)
- Secondary air injection pump relay (K64)
- Soft top opening relay (K66/1) (only cabrio)
- Soft top closing relay (K66/2) (only cabrio)

i Note

Up to six transmitter keys can be stored in the SAM control unit.

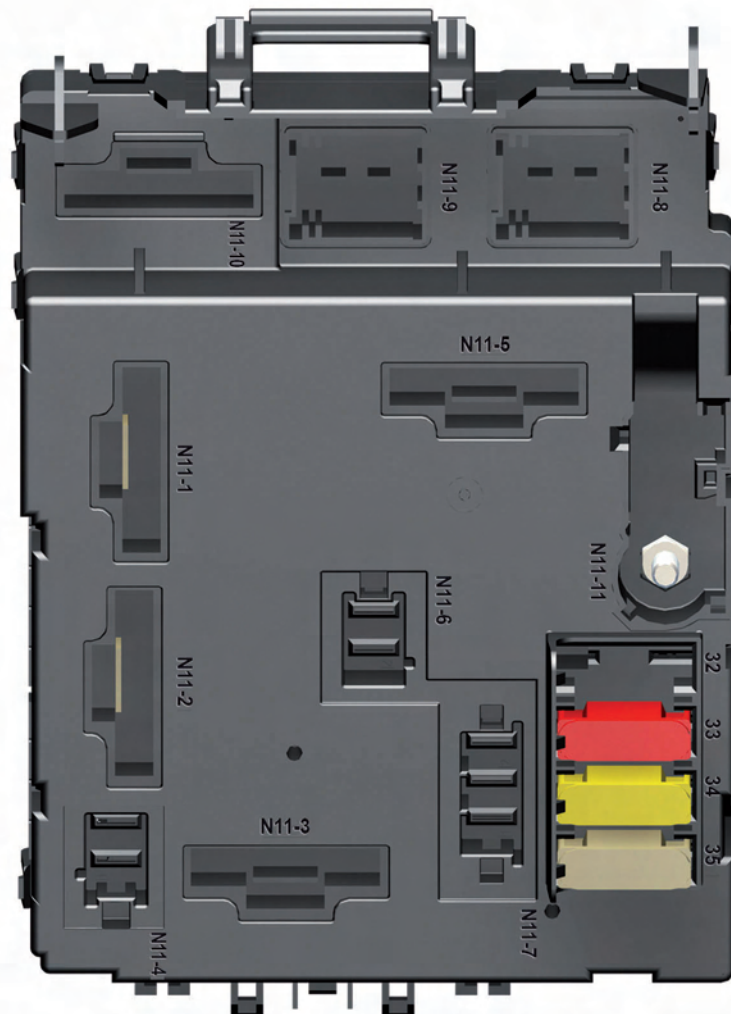

SAM control unit (rear)

P54.21-2703-00

Engine description

Engine M132

At market launch, the smart fortwo is available with a 3-cylinder gasoline engine with 61 in³ (999 cm³) displacement and 52 kW



3-cylinder gasoline engine (M132)

P01.10-2942-00

Performance graph

Engine M132

Power and torque graph

The red characteristic represents the power curve (P) in relation to the engine speed (n).
The blue characteristic represents the torque curve (M) in relation to the engine speed (n).

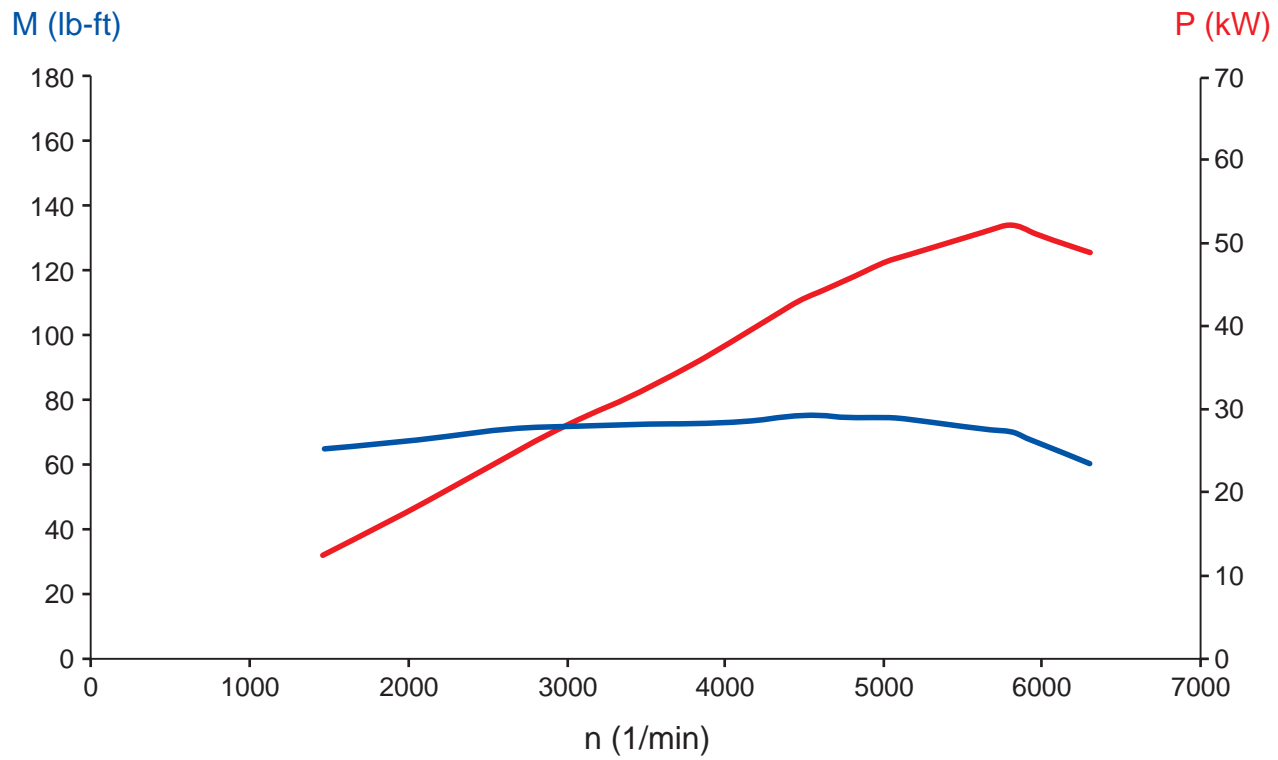

Power and torque graph M132

P01.00-2999-00

M Torque (lb-ft)
P Engine power (kW)
n Engine speed (rpm)

Engine data

M132		
Engine model designation		132.910
Rated output	kW at rpm	52 5800
Rated torque	lb-ft (Nm) at rpm	68 (92) 4500
Compression ratio	e	10.0:1
Engine configuration/no. of cylinders		Inline/3
Camshaft configuration/number		Overhead/2
Displacement	in ³ (cm ³)	61 (999)
Bore	in (mm)	2.83 (72)
Stroke	in (mm)	3.22 81.8
Cylinder angle	°	45
Fuel		* Premium gasoline unleaded
Emission regulations		ULEV

* Fuel requirements:

Only unleaded premium fuel may be used. The octane number (shown on the gasoline pump) should be at least 91. This is an average value based on tests of the octane number (RON) and motor octane number (MON) $(RON+MON/2)$. It is also known as the anti-knock index.

Valve assembly

Valve assembly

The timing chain is driven by the crankshaft via the crankshaft gear and thus drives the intake camshaft via the camshaft adjuster and the exhaust camshaft via the exhaust camshaft sprocket. The timing chain is guided by a slide rail. A tensioning rail and chain tensioner ensure that the chain is at the right tension to prevent wear and noises.

The intake and exhaust camshafts control the gas exchange in the engine via the intake and exhaust valves. Variable camshaft adjustment allows for greater torque at low engine speeds and better response time in the idle and partial-load ranges. At the same time, the camshaft adjustment helps to achieve the stipulated exhaust emissions limits.

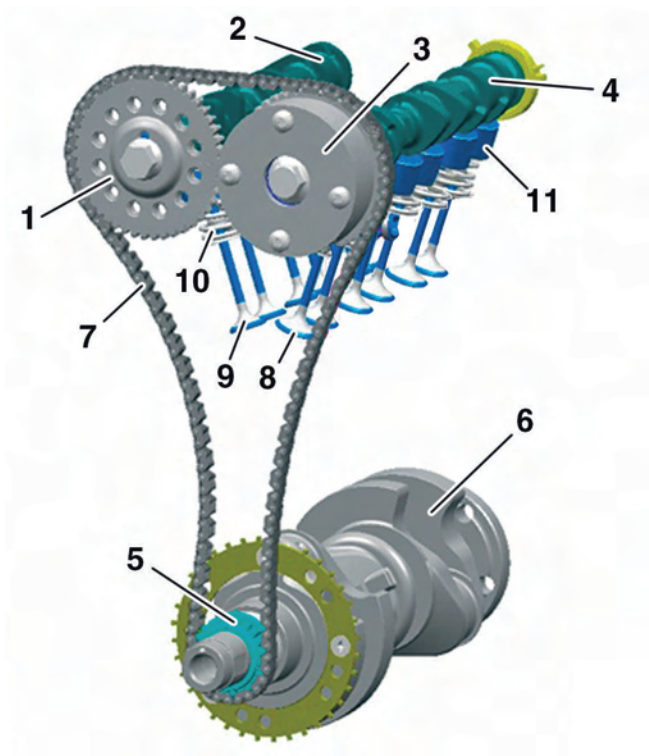

P05.00-2082-00

Valve assembly

- | | |
|-----------------------------|-----------------|
| 1 Exhaust camshaft sprocket | 7 Timing chain |
| 2 Exhaust camshaft | 8 Intake valve |
| 3 Camshaft adjuster | 9 Exhaust valve |
| 4 Intake camshaft | 10 Valve spring |
| 5 Crankshaft gear | 11 Cup tappet |
| 6 Crankshaft | |

Valve timing

General

Engine M132 is equipped with mechanical cup tappets. The mechanical stress on the cams and cup tappets makes it necessary to check and adjust the valve clearance.

The cup tappets must be measured using a micrometer.

Find and insert the appropriate cup tappet by reference to its markings.

The valve clearance is adjusted by exchanging the cup tappets. These are available in various thicknesses.

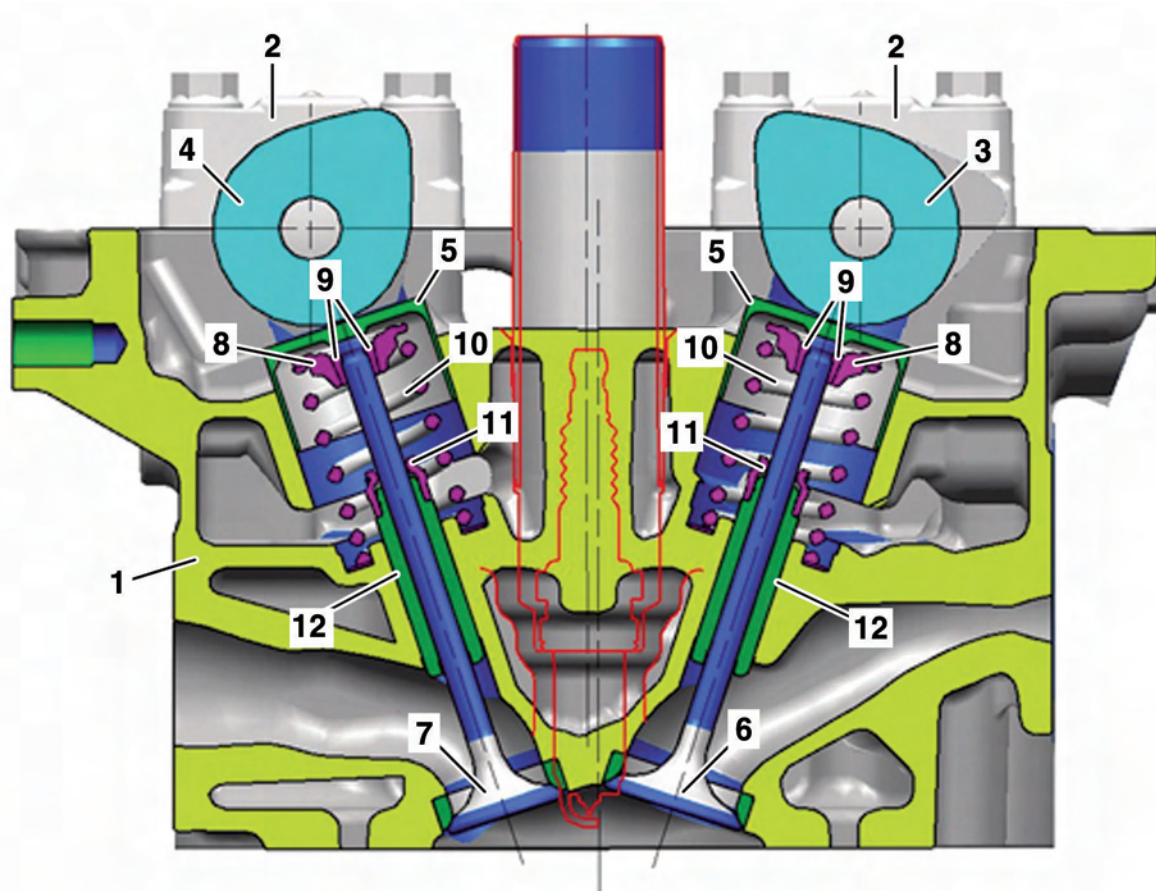

P05.30-2151-00

- | | |
|------------------------|-------------------------|
| 1 Cylinder head | 7 Exhaust valve |
| 2 Camshaft bearing cap | 8 Valve spring retainer |
| 3 Intake camshaft | 9 Valve locks |
| 4 Exhaust camshaft | 10 Valve spring |
| 5 Cup tappet | 11 Valve stem seal |
| 6 Intake valve | 12 Valve seat |

Gasoline injection and ignition system

Injection control

Engine M132 features an ME (motor electronics) gasoline injection and ignition system. The central control unit of this system is the ME-SFI [ME] control unit. It is networked over CAN with the following components:

- Instrument cluster
- SAM control unit
- Automated manual transmission control unit
- Heater/AC operating unit
- ESP control unit
- Steering assist control unit
- Data link connector

The ME-SFI [ME] control unit puts its information on the CAN, making it accessible to all the other networked components on the CAN. The information from other components reaches the ME-SFI [ME] control unit in the same way. For example, the signal from the clutch motor, which is read directly by the automated manual transmission control unit, reaches the ME-SFI [ME] control unit in this way.

Direct input signals come from:

- Knock sensor
- Fuel tank pressure sensor
- Camshaft Hall sensor
- Coolant temperature sensor
- Accelerator pedal sensor
- O₂ sensor downstream of TWC [KAT]
- O₂ sensor upstream of TWC [KAT]
- Crankshaft position sensor
- Throttle valve actuator
- Oil pressure switch

Direct output signals go to:

- Fuel pump relay
- Fuel pump with fuel level sensor
- Secondary air injection pump relay
- Secondary air injection pump
- Secondary air injection pump switchover valve
- Throttle valve actuator
- Cylinder 1 ignition coil
- Cylinder 2 ignition coil
- Cylinder 3 ignition coil
- Outside air shutoff valve
- Adjustable camshaft timing solenoid
- Cylinder 1 fuel injection valve
- Cylinder 2 fuel injection valve
- Cylinder 3 fuel injection valve
- Fuel tank vent valve

There are also the following inputs on the ME-SFI [ME] control unit:

- Circuit 15
- Circuit 30
- Circuit 31

Function

The engine is controlled according to load by the performance map based on the signals arriving either directly or over CAN. The actuators are actuated via direct lines in accordance with the values computed by the ME-SFI [ME] control unit. Information intended for other components is put on the CAN.

The ME-SFI [ME] control unit has an integral fault memory and can exchange information with STAR DIAGNOSIS via a data link connector that is connected to the CAN.

Gasoline injection and ignition system

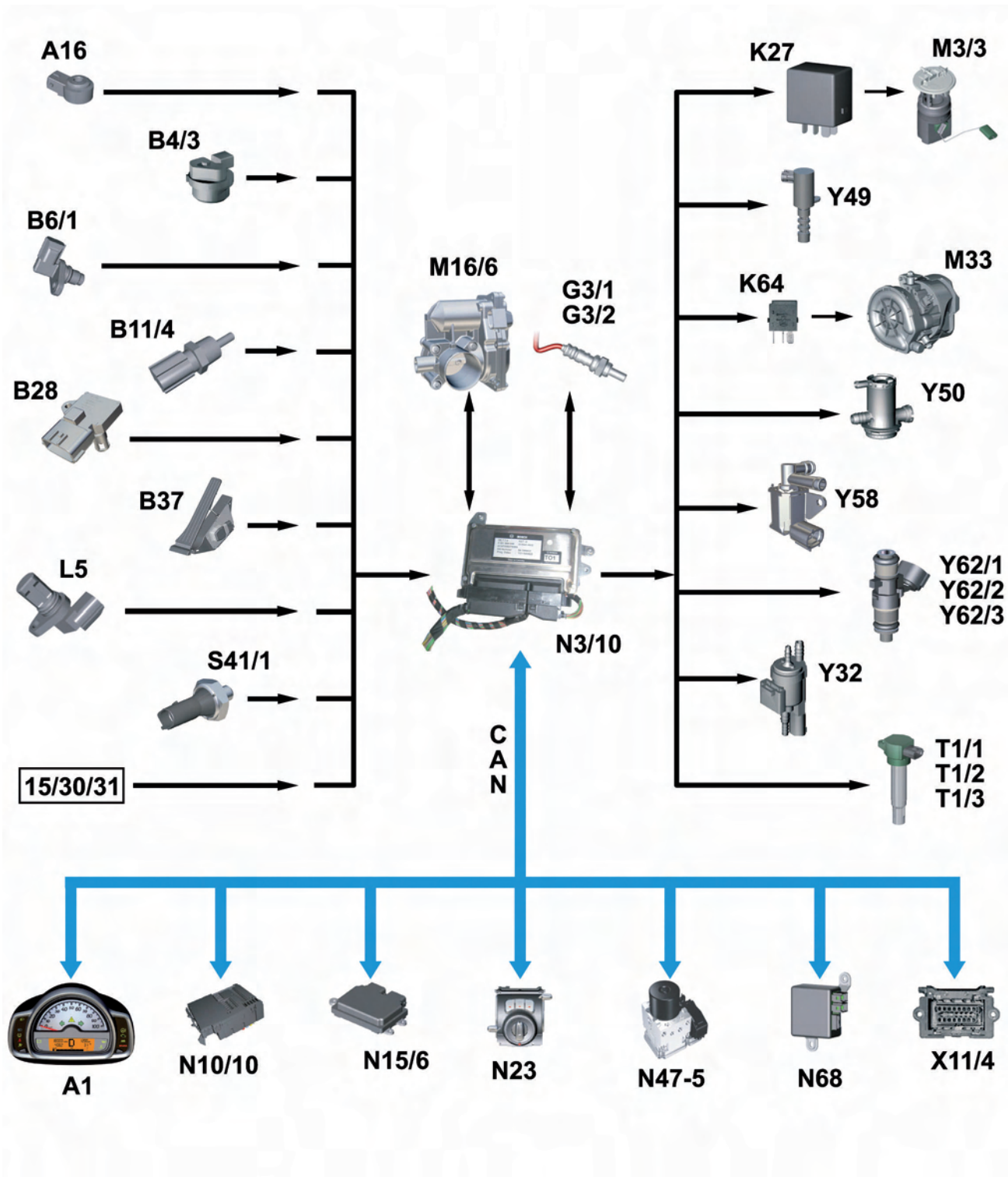

Data flow chart of M132 injection system

P07.61-3578-00

Gasoline injection and ignition system

Engine M132

15/30/31 Circuit status

A1	Instrument cluster	N10/10	SAM control unit
A16	Knock sensor	N15/6	Automated manual transmission control unit
B4/3	Fuel tank pressure sensor	N23	Heater/AC operating unit
B6/1	Camshaft Hall sensor	N47-5	ESP control unit
B11/4	Coolant temperature sensor	N68	Steering assist control unit
B28	Intake manifold pressure sensor	S41/1	Oil pressure switch
B37	Accelerator pedal sensor	T1/1	Cylinder 1 ignition coil
G3/1	O2 sensor downstream of TWC [KAT]	T1/2	Cylinder 2 ignition coil
G3/2	O2 sensor upstream of TWC [KAT]	T1/3	Cylinder 3 ignition coil
K27	Fuel pump relay	X11/4	Data link connector
K64	Secondary air injection pump relay	Y32	Secondary air injection pump switchover valve
L5	Crankshaft position sensor	Y49	Adjustable camshaft timing solenoid
M3/3	Fuel pump with fuel level sensor	Y50	Outside air shutoff valve
M16/6	Throttle valve actuator	Y58	Tank vent valve
M33	Secondary air injection pump	Y62/1	Cylinder 1 fuel injection valve
N3/10	ME-SFI [ME] control unit	Y62/2	Cylinder 2 fuel injection valve
		Y62/3	Cylinder 3 fuel injection valve
		CAN	Controller Area Network (data bus/CAN bus)

Belt drive

Belt adjustment and description of stretch belt

Self-tensioning belt drive

The alternator and coolant pump are driven by a poly-V belt with tensioning device.

The poly-V belt is tensioned via a new spring-loaded tensioning device. To install and remove the poly-V belt the tensioning device must be rotated clockwise using a special tool to slacken the tension in the belt drive. The tensioning device can then be locked in place and the poly-V belt removed.

Stretch belt

The refrigerant compressor is driven by a stretch belt.

The stretch belt does not need a tensioning device, but it must be replaced after a specified mileage. It is removed and installed with the aid of a special tool that guides the stretch belt over the belt pulley of the refrigerant compressor. The stretch belt can be pulled on or off the belt pulley by cranking the engine in its normal direction of rotation.

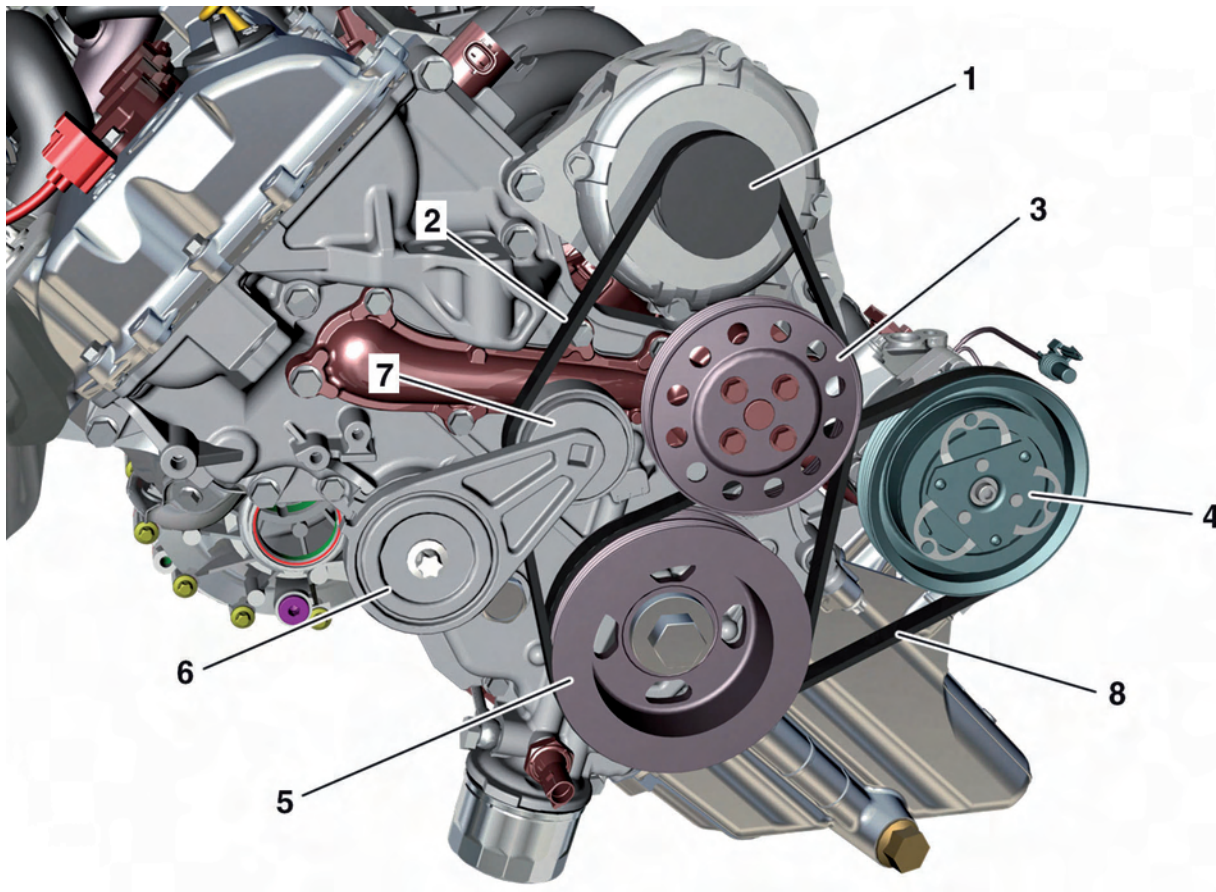

P13.20-2055-00

Belt drive

- | | |
|--------------------------------------|---------------------------------|
| 1 Alternator belt pulley | 5 Crankshaft pulley |
| 2 Poly-V belt | 6 Tensioning device |
| 3 Coolant pump belt pulley | 7 Tensioning device belt pulley |
| 4 Refrigerant compressor belt pulley | 8 Stretch belt |

Cooling system

Coolant circuit

In the small cooling circuit, the coolant is pumped through the engine, the heater heat exchanger and back to the engine via the expansion reservoir by the coolant recirculation pump.

In the large coolant circuit, the coolant flows from the thermostat straight to the radiator and on to the coolant recirculation pump.

The switchover between the small and large coolant circuit is performed by the thermostat depending on the coolant temperature.

In the expansion reservoir the circuit is split again, with one stream flowing direct to the coolant recirculation pump and the other passing through the radiator.

The coolant fan motor is switched on or off depending on the engine temperature recorded by the coolant temperature sensor and cools the coolant.

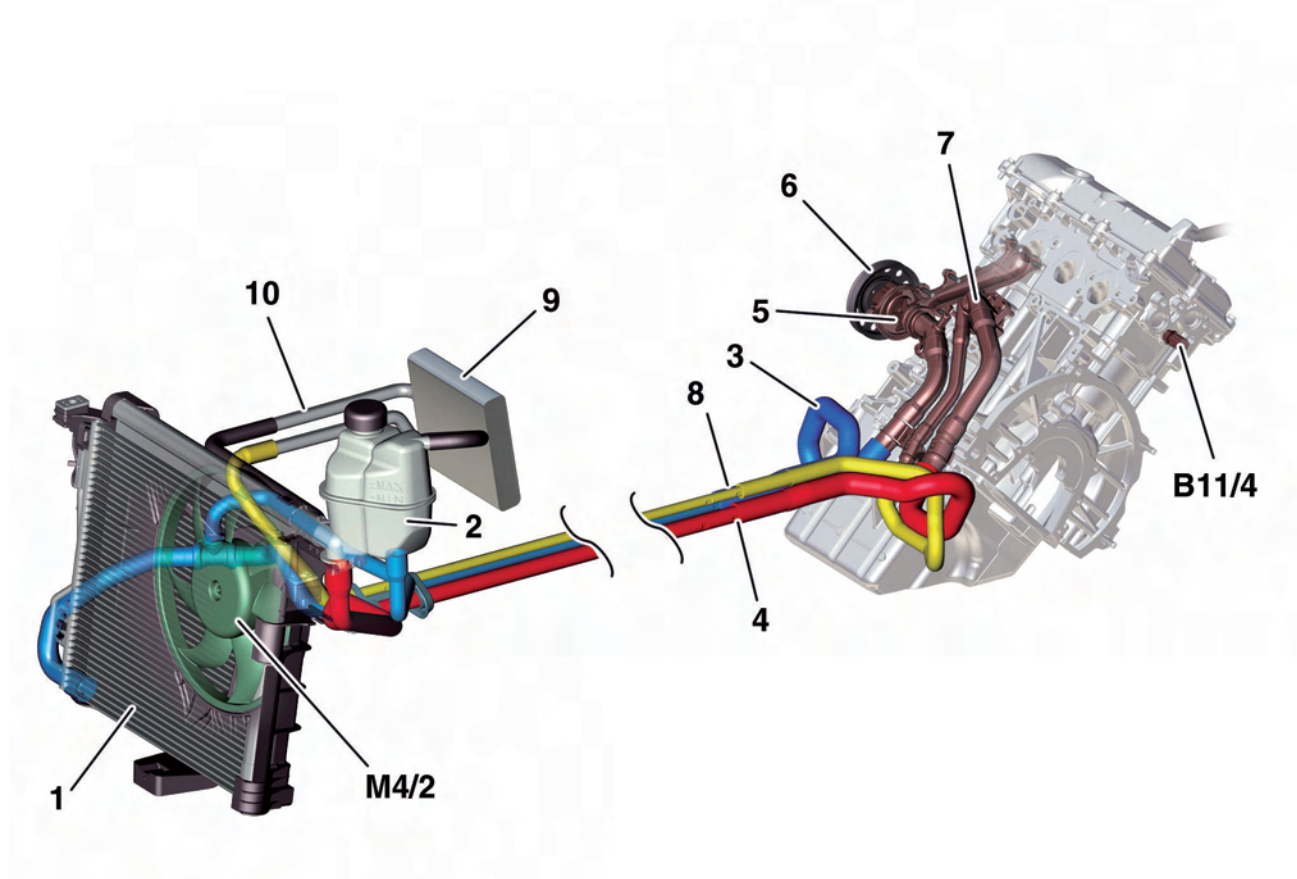

P20.00-2339-00

- 1 Radiator
- 2 Expansion reservoir
- 3 Coolant return line
- 4 Coolant feed line (large circuit)
- 5 Coolant pump
- 6 Coolant pump belt pulley
- 7 Thermostat

- 8 Coolant feed line (small circuit)
- 9 Heater heat exchanger
- 10 Coolant pipe
- B11/4 Coolant temperature sensor
- M4/2 Coolant fan motor

Cooling system

Bleeding cooling system

General

If some or all of the coolant has been drained, the cooling system must be bled after refilling.

Fill

Unscrew the cooling system cap and fill the cooling system up to the "MAX" mark in the expansion reservoir.

i Note

The cooling system must be filled and bled only when the engine is cold.

Bleeding

Unfasten the clamp, pull off the coolant hose and wait until coolant emerges from the coolant hose and the cylinder head. Then reconnect the coolant hose and fasten it with the clamp.

Top up the expansion reservoir to the "MAX" mark again and screw on the cooling system cap.

Warm up the engine until the thermostat opens. Switch off the engine and check the coolant level in the expansion reservoir.

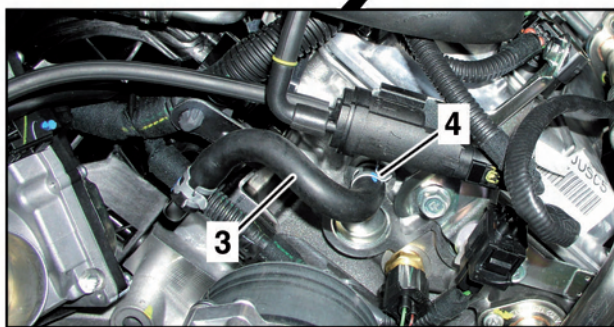
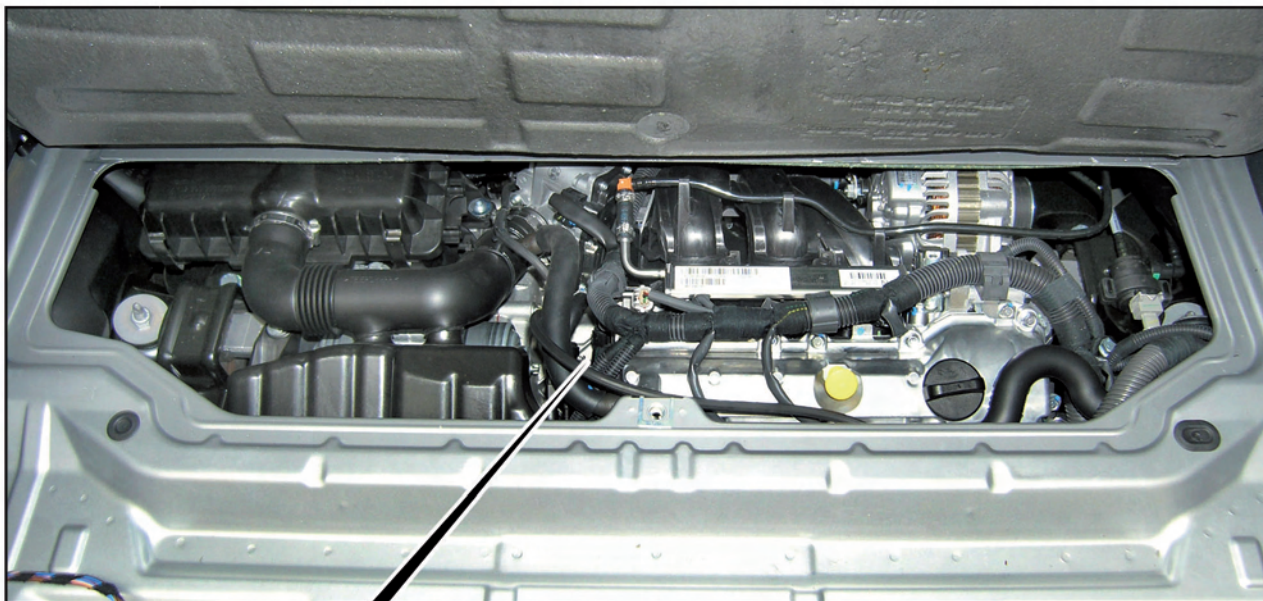

1 Cooling system cap
2 Expansion reservoir

3 Coolant hose
4 Clamp

P20.00-2340-00

Engine mount/torque support

The engine with transmission is mounted on two mounts and a torque support. They were designed to dampen inherent engine vibrations. They also considerably reduce the rocking of the drive assemblies during load changes. The reduction in vibrations and in the tendency to rock provides a higher level of driving safety and ride comfort.

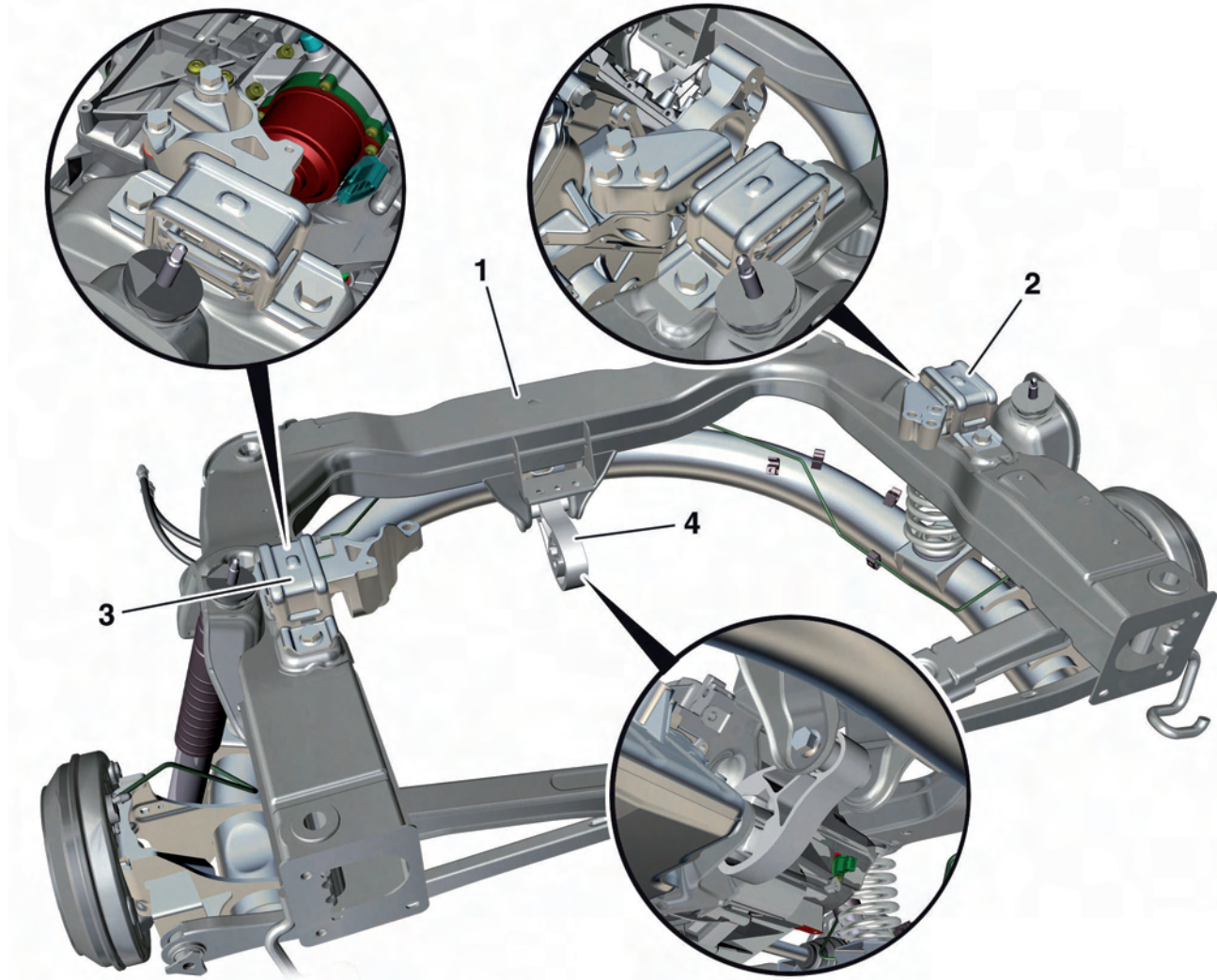

Engine mount, transmission mount and torque support

P22.10-2299-00

1 *Frame-type integral support*
2 *Engine mount*

3 *Transmission mount*
4 *Torque support*

Fuel supply

Fuel supply

A non-return fuel system is used for the fuel supply. The fuel is pumped by a flow pump via the fuel filter in the fuel tank into the fuel distributor rail according to requirements.

Any surplus fuel is pumped via the fuel pressure regulator straight into the buffer of the fuel pump. The fuel pressure regulator is designed to ensure that there is always a pressure of 46 psi (3.24 bar) at the fuel distributor rail. The fuel tank fill level is measured by a float-and-lever sensor.

Fuel tank

The fuel tank is located in front of the rear axle under the seats. It is made of polyethylene and is formed such that the available installation space is used to an optimum. The capacity of the fuel tank is 8.72 gallons (33 liters), including a 1.32 gallon (5 liter) reserve.

The intank fuel supply system consists of a fuel pump with fuel level sensor, fuel pressure regulator and an integrated fuel filter.

Evaporative emission control system (purging)

The evaporative emission control system prevents fuel vapors escaping to the atmosphere. The fuel vapors are stored in the activated charcoal filter and then sent later to the engine for combustion.

Leak test

The leak test for the fuel evaporation control system must detect leaks with a diameter as of 0.02 in (0.5 mm) and must take place in three stages (function chain):

- Test for gross leaks (equal to or greater than 0.12 in (3 mm))
- Test for fine leaks (equal to or greater than 0.04 in (1 mm))
- Test for very fine leaks (equal to or greater than 0.02 in (0.5 mm))

Test for gross leaks

The outside air shutoff valve is closed and the tank vent valve is opened. Intake manifold vacuum present in fuel tank. This vacuum is measured by the tank pressure sensor.

If no vacuum is built up in the fuel tank (approx. -0.1 psi (-6 mbar) within approx. 12 seconds) there is a major leak (e.g. tank cap open, hose line loose). The test will be interrupted and the "gross leak" fault will be registered.

If the ME-SFI [ME] control unit detects a system with a gross leak, the fuel reserve warning lamp in the instrument cluster flashes and the message "CHECK FILLER CAP" appears in the multifunction display.

Test for fine leaks

The tank vent valve is closed at a vacuum of around -0.1 psi (-6 mbar). The system is closed and thereby airproof. The vacuum is then measured for approx. 30 seconds. The vacuum must not reduce more rapidly than 0.004 to 0.007 psi/s (0.3 to 0.5 mbar/s) (depends on fuel level). If the vacuum drops more rapidly, there is a fine leak.

The test will be interrupted and the "fine leak" fault will be registered.



Check for very fine leaks

If no fine leak is recognized then purging is briefly enabled and then the vacuum of about -0.1 psi (-6 mbar) is built up again. The vacuum must not reduce more rapidly than 0.0014 to 0.002 psi/s (0.1 to 0.15 mbar/s) in the closed system (depends on fuel level).

If the vacuum drops more rapidly, the fault "very fine leak" will be registered.

The reduction in vacuum depends on the fuel level in the fuel tank and on outgassing of the fuel. The outgassing of the fuel is measured just before the test by the fuel tank pressure sensor and is allowed for during fault determination.

The test for fine and very fine leaks is aborted if an excessive lean correction of the lambda control takes place during the build-up of the vacuum.

The function of the tank vent valve is checked at the same time by the actuation. If the closed tank vent valve jams, the fault "gross leak" is stored.

Test requirements

- Engine at idle
- Vehicle stationary
- Drive position "D" or "R" is engaged
- Off-period after engine start elapsed (approx. 16 minutes) or mixture adaptation performed
- Lambda control enabled
- Intake air temperature <113° F (<45 °C)
- Coolant temperature at engine start <212° F (<100 °C)
- Air injection not active
- Air pressure >1.12 psi (>780 hPa) (i.e. no tests performed above approx. 2735 yd (2500 m) altitude)
- Low loading of activated charcoal canister
- Fuel level in fuel tank between approx. ¼ and ¾
- No fault in outside air shutoff valve
- No fault in the fuel tank pressure sensor
- No fault in tank vent valve
- Battery voltage > 11 V

The outside air shutoff valve is reopened after the tests.

Fuel supply

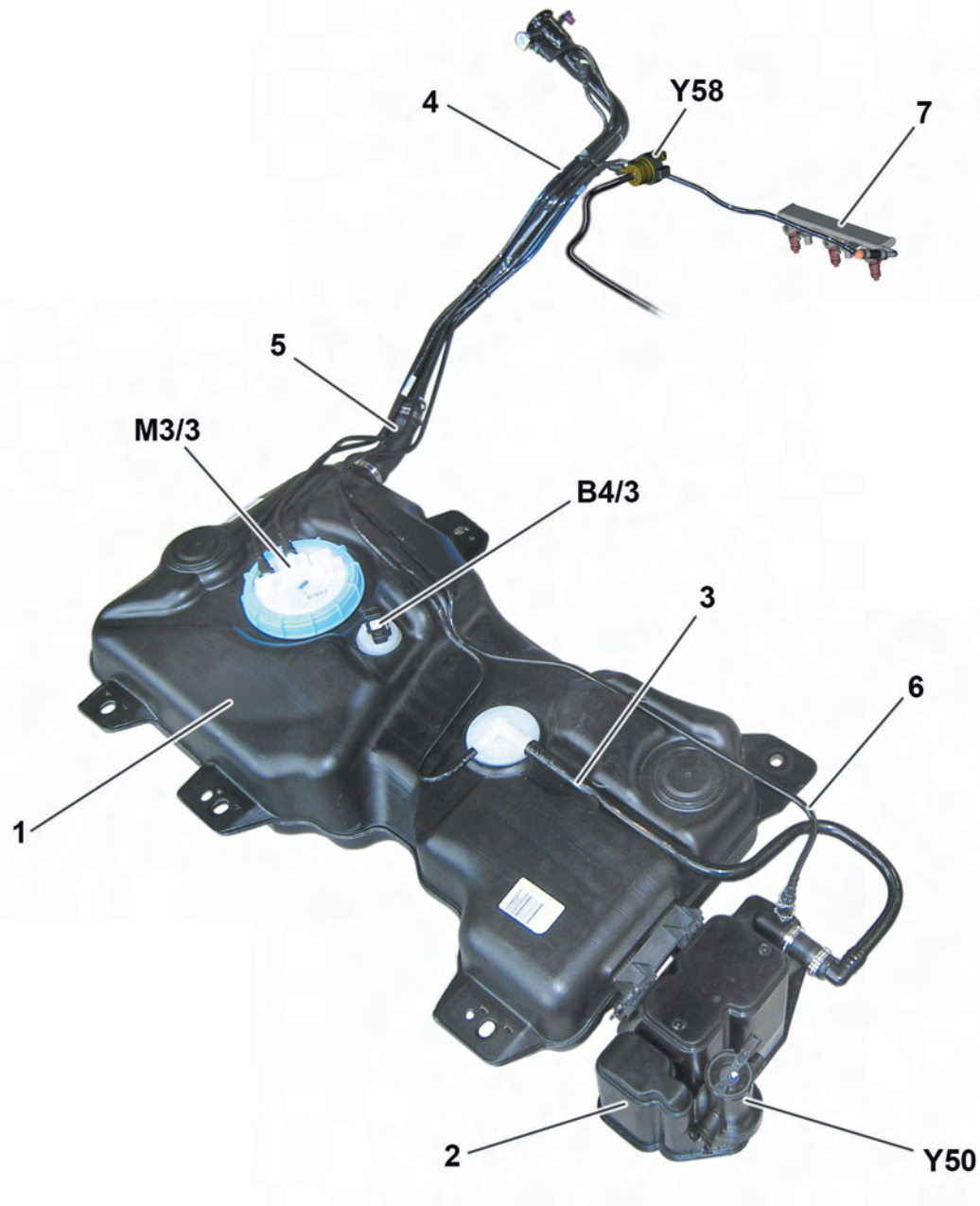

P47.-10-2433-00

Fuel system

- | | |
|-------------------------------|---------------------------------------|
| 1 Fuel tank | B4/3 Fuel tank pressure sensor |
| 2 Activated charcoal filter | M3/3 Fuel pump with fuel level sensor |
| 3 Vent line | Y50 Outside air shutoff valve |
| 4 Filler neck | Y58 Tank vent valve |
| 5 Filler neck hose connection | |
| 6 Purge line | |
| 7 Fuel distributor rail | |

Design

The exhaust system is made of stainless steel and consists of the following components:

- Exhaust manifold
- Catalytic converter
- Main muffler

Muffler system

When designing the muffler systems, it was important both to minimize the exhaust back pressure and achieve optimum acoustic tuning. The muffler system is rigidly fixed to the vehicle body.

Exhaust aftertreatment

A control sensor and a diagnostic sensor are installed for exhaust aftertreatment.

Aftertreatment of the exhaust gases is performed by a catalytic converter with monolithic coating.

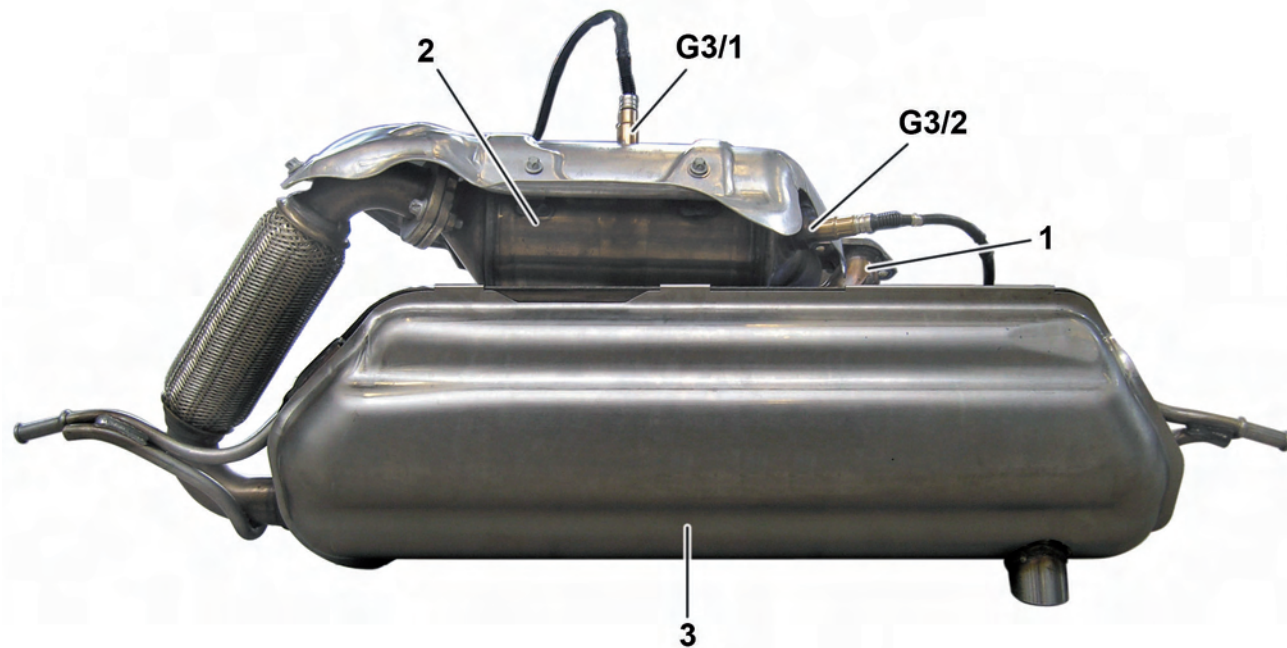

P49.00-2109-00

Exhaust system

- 1 Exhaust manifold
- 2 Catalytic converter
- 3 Main muffler

- G3/1 O₂ sensor downstream of TWC [KAT]
G3/2 O₂ sensor upstream of TWC [KAT]

Secondary air injection

Secondary air injection

Engine 132 is fitted with a secondary air injection pump (electric air pump), which injects additional fresh air in order to reduce exhaust gas emissions after a cold start and to accelerate the warming of the catalytic converter to its reaction temperature.

The necessary air is injected into the exhaust ports in the cylinder head by the secondary air injection pump via the combination valve. The secondary air injection pump is actuated by the ME-SFI [ME] control unit via a relay.

The secondary air injection pump switchover valve is supplied with vacuum from the vacuum reservoir at the intake manifold via a check valve.

When actuated, the secondary air injection pump switchover valve releases vacuum to the combination valve. This opens and the air injected by the secondary air injection pump passes through to the exhaust ports in the cylinder head.

The injected air reacts with the hot exhaust gases in the outlet port. The carbon monoxide (CO) and hydrocarbon (HC) are oxidized. This "afterburning" process increases the exhaust temperature and reduces pollutants.

The duration of secondary air injection is dependent on the coolant temperature.

The secondary air injection pump is only actuated at a coolant temperature of 45 °F to 97 °F (7 °C to 36 °C) and for a maximum duration of 33 seconds.

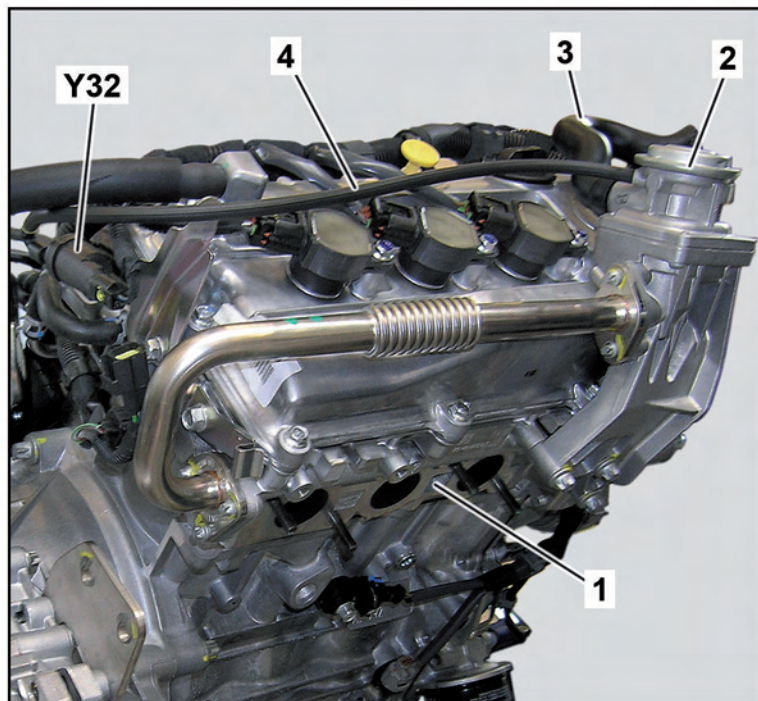

Secondary air injection

- 1 Cylinder head
- 2 Combination valve
- 3 Air hose
- 4 Vacuum hose

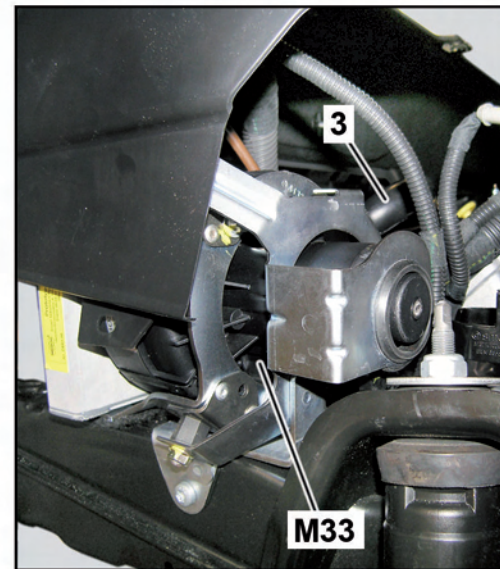

- M33 Secondary air injection pump
- Y32 Secondary air injection pump switchover valve

P14.30-2183-00

Transmission description

5-speed automated manual transmission (AMT 2)

The smart fortwo is fitted with the newly developed 2nd generation 5-speed automated manual transmission (AMT 2).

Advantages of the 5-speed automated manual transmission:

- Greater shift comfort
- Reduced fuel consumption

Features:

- 5-speed transmission
- Two-drum control
- Potentiometer-free position sensor system
- Mechanical park pawl

The driver can choose between two operating modes:

- Automatic mode (selector lever in position "D")
- Manual mode (selector lever in position M "+/-") with operation via the selector lever or paddle shifts on the steering wheel (SAL)



5-speed manual transmission (AMT 2)

P26.10-2167-00

Transmission description

AMT 2 in model 451		
	Unit	
Transmission model	G	717.482
Number of forward/reverse gears		5/1
Max. transferable torque	lb-ft (Nm)	88 (120)
Clutch		Single-plate dry clutch
Overall length (including 3 in (75 mm) for clutch)	in (mm)	14.3 (364)
Housing material		Aluminum alloy
Weight (without oil charge)	lb (kg)	Approx. 74.9 (34)
Oil charge (permanent charge)	US qt (l)	2.4 (2.3)
Housing		Two-piece with bell housing

Shift mechanism

Shift mechanism

The central components of the shift mechanism are two selector drums for moving the shift forks. Each selector drum is driven by a separate electric motor via two sintered spur gear sets. One selector drum shifts the odd gears, while the other shifts the even gears and reverse gear.

The position of the selector drum, and thus the current shift position, is determined by two incremental sensors in each electric motor.

Both electric motors and the spur gears are located in a common aluminum housing, the actuator unit, which is mounted on the transmission.

The two selector drums are arranged to allow overlapping shift operations to minimize shift times. It is possible to skip gears (e.g. double downshifts).

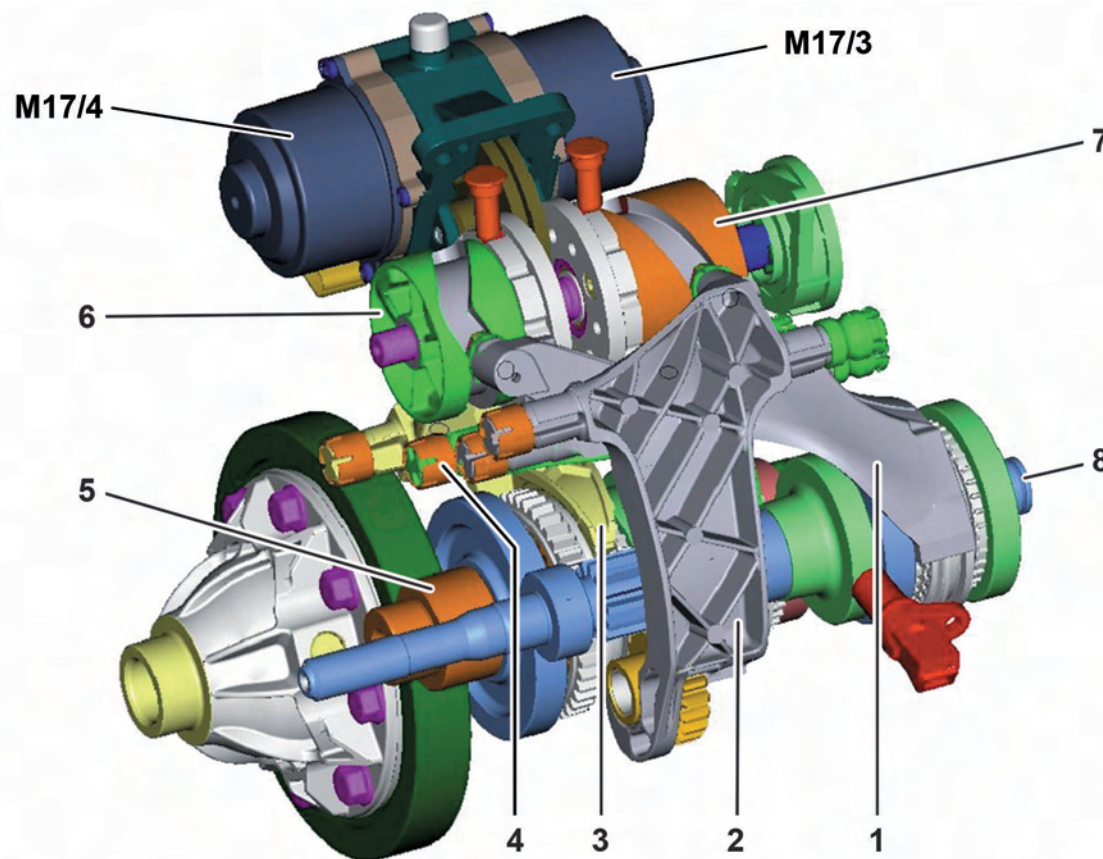

P26.60-2320-00

Design of shift mechanism

- | | | | |
|---|--|-------|----------------------|
| 1 | Shift fork for shift collar 5 | 6 | Selector drum 1/3, 5 |
| 2 | Shift fork for reverse gear sliding gear | 7 | Selector drum 2/4, R |
| 3 | Shift fork for shift collar 1/3 | 8 | Input shaft |
| 4 | Shift fork for shift collar 2/4 | M17/3 | Transmission motor 1 |
| 5 | Main shaft | M17/4 | Transmission motor 2 |

Shift mechanism

Function

The shift forks are displaced by the selector drums parallel to the transmission shafts. They in turn slide the shift collars on the input shaft or the main shaft towards the respective idler gears.

The actuation of the shift forks is conducted by two independent selector drums, each of which has a groove. The sliding blocks for two shift forks run in each groove.

Shift positions

Neutral (N) and reverse gear (R)

- a Selector drum 1/3, 5
- b Selector drum 2/4, R
- c Selector drum adjustment (1 grid square = 40°)
- d Sliding block deflection (1 grid square = 0.3 in (7.5 mm))

Neutral position (N)

The sliding blocks in the grooves of the selector drum are in the neutral position. No gear is engaged.

Selector drum 1/3, 5:

- Sliding block of shift fork for shift collar 1/3
- Sliding block of shift fork for shift collar 5

Selector drum 2/4, R:

- Sliding block of shift fork for shift collar 2/4
- Sliding block of shift fork for sliding gear, reverse gear

The positions of both sliding blocks in the same groove are offset to each other by 120°. If a sliding block displaces a shift fork from the center position, the other sliding block is in the straight area of the groove (in center position of respective shift fork).

Reverse gear (R)

The selector drum 2/4, R rotates through 120° downwards. This displaces the upper sliding block by 0.89 in (22.5 mm) to the left. The reverse gear sliding gear engages in the outer teeth of shift collar 1/3.

The sliding blocks in the selector drum 1/3, 5 are in the neutral position.

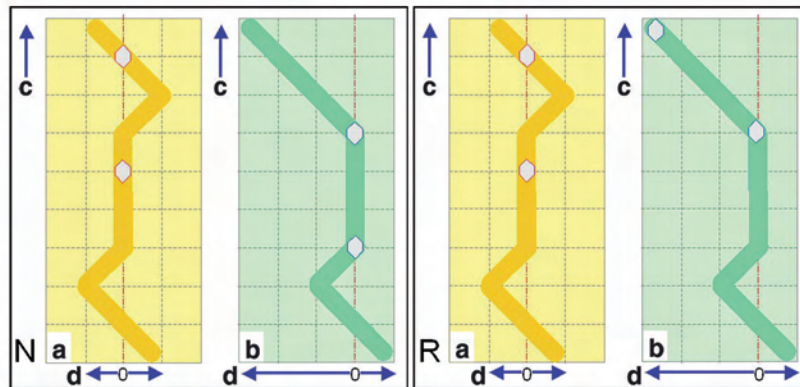
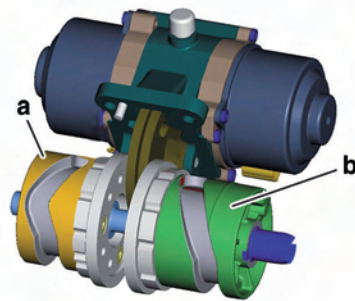

P26.60-2356-00

Shift mechanism

Shift positions

1st gear (1) and 2nd gear (2)

- a Selector drum 1/3, 5
- b Selector drum 2/4, R
- c Selector drum adjustment (1 grid square = 40°)
- d Sliding block deflection (1 grid square = 0.3 in (7.5 mm))

1st gear (1)

The selector drum 1/3, 5 rotates through 40° downwards. This displaces the upper sliding block by 0.3 in (7.5 mm) to the left. The shift collar 1/3 is slid into the idler gear of the first gear. The sliding blocks in the selector drum 2/4, R are in the neutral position.

2nd gear (2)

For the change from 1st gear to 2nd gear, the two selector drums rotate through 40° upwards. This in turn displaces the lower sliding block in the selector drum 2/4, R by 0.3 in (7.5 mm) to the left. The shift collar 2/4 is slid into the idler gear of the second gear. The sliding blocks in the selector drum 1/3, 5 are in the neutral position.,

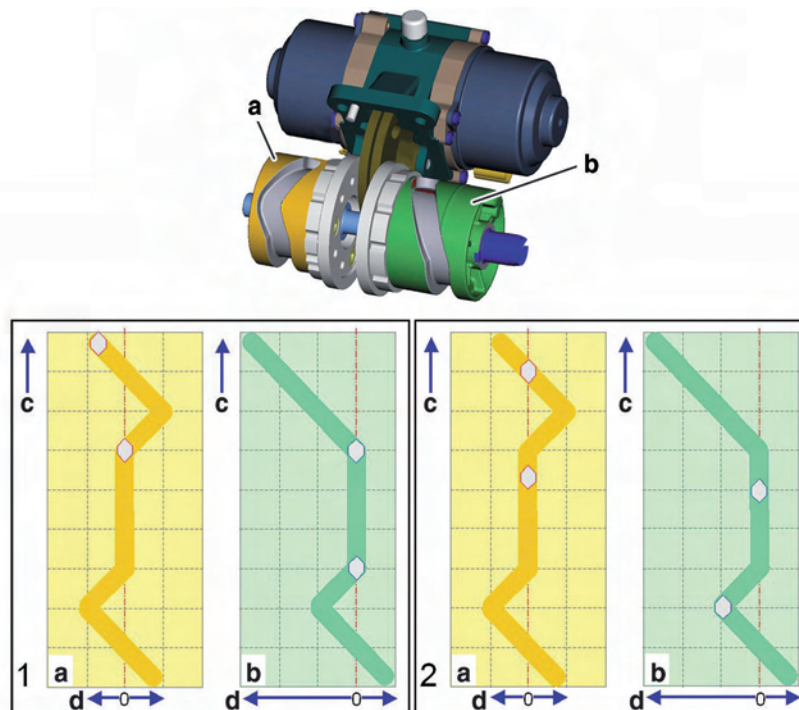

P26.60-2357-00

Shift mechanism

Shift positions

3rd gear (3) and 4th gear (4)

- a Selector drum 1/3, 5
- b Selector drum 2/4, R
- c Selector drum adjustment (1 grid square = 40°)
- d Sliding block deflection (1 grid square = 0.3 in (7.5 mm))

3rd gear (3)

For the change from 2nd gear to 3rd gear, the two selector drums rotate through 40° upwards. The upper sliding block in the selector drum 1/3, 5 is displaced by 0.3 in (7.5 mm) to the right. It presses the shift collar 1/3 into the idler gear of the third gear. The other sliding blocks are in the neutral position.

4th gear (4)

For the change from 3rd gear to 4th gear, the two selector drums rotate through 40° upwards. The lower sliding block in the selector drum 2/4, R is displaced by 0.3 in (7.5 mm) to the right. It presses the shift collar 2/4 into the idler gear of the fourth gear. The other sliding blocks are in the neutral position.

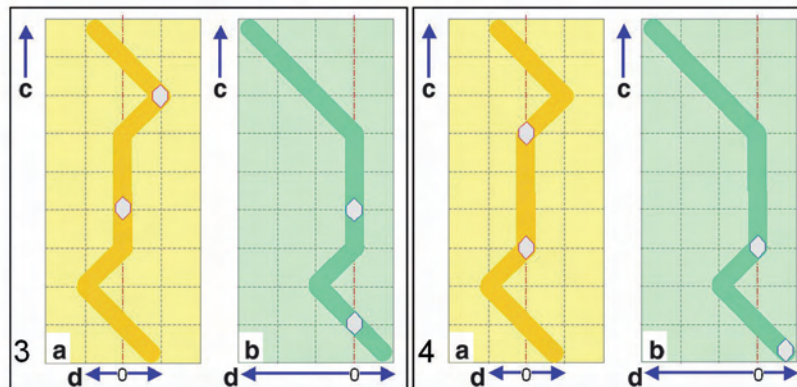
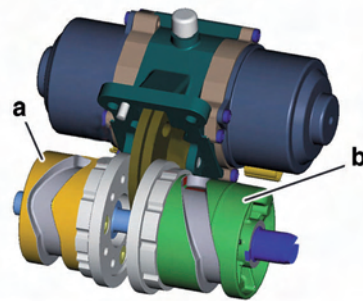

P26.60-2358-00

Shift mechanism

Shift positions

5th gear (5)

- a Selector drum 1/3, 5
- b Selector drum 2/4, R
- c Selector drum adjustment (1 grid square = 40°)
- d Sliding block deflection (1 grid square = 0.3 in (7.5 mm))

5th gear (5)

For the change from 4th gear to 5th gear, the selector drum 1/3, 5 rotates through 40° upwards. The lower sliding block in the selector drum 1/3, 5 is displaced by 0.3 in (7.5 mm) to the left. It presses shift collar 5 into the idler gear of the fifth gear. The selector drum 2/4, R is rotated through 40° downwards. The sliding blocks in the selector drum 2/4, R are in the neutral position.

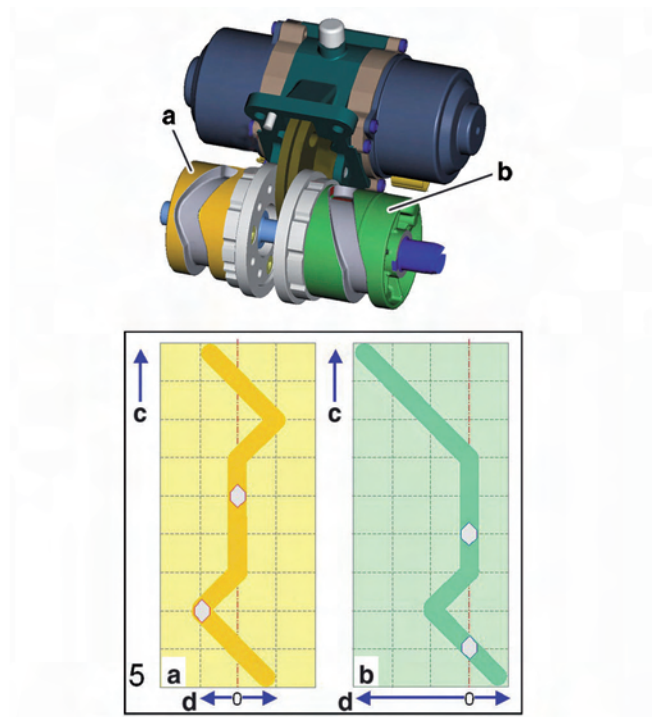

P26.60-2362-00

Synchronization

Borg-Warner synchronization

All forward gears are equipped with a Borg-Warner synchronization.

Reverse gear is not synchronized.

Function

Before the shift collar (3) positively connects the sleeve carrier with the corresponding idler gear, the tapered pairs of faces contact the clutch body (1), synchronizer ring (2) and, where applicable, an intermediate ring. The engine's gear is run at the speed of the corresponding drive-side gear; only then do the locking splines (4) release the remaining travel of the shift collar. The shift collar travel from neutral to complete engagement in the relevant idler gear is approx. 0.3 in (7.7 mm).

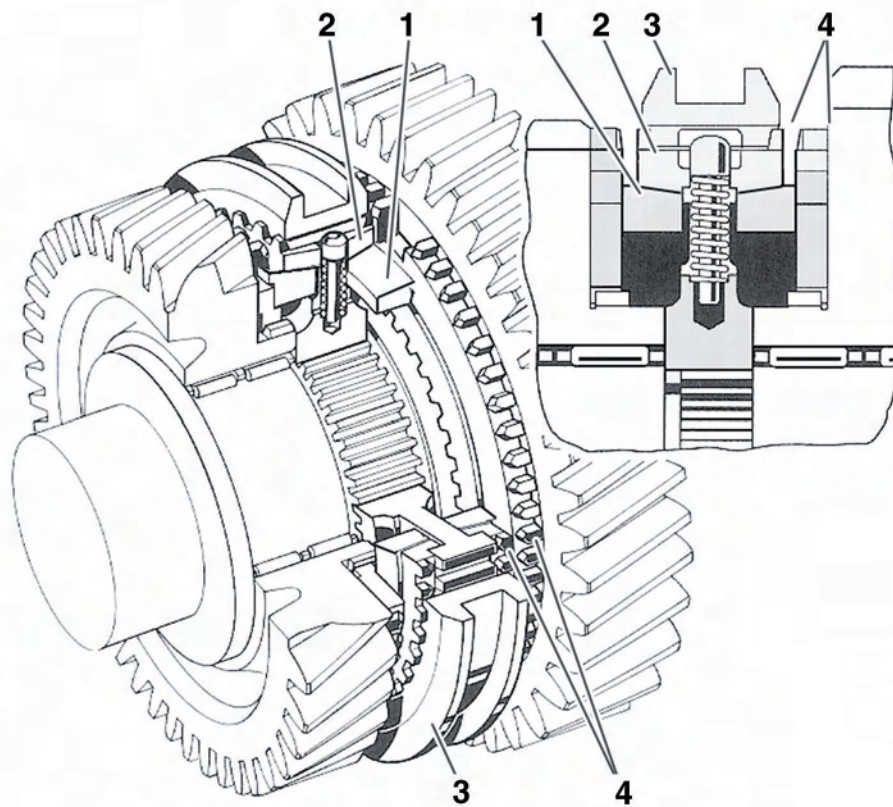

- 1 Clutch body
- 2 Synchronizer ring
- 3 Shift collar
- 4 Locking splines

P26.50-2173-00

Transmission control

Transmission rpm sensor (L2)

Location

The transmission rpm sensor is mounted to the transmission housing.

Task

The rpm sensor determines the rotational speed of the input shaft. The recorded speeds of the crankshaft and input shaft are used to monitor the clutch operation. The speeds of the input shaft and the drive wheels are used to determine the actual gear engaged.

The diagram illustrates the oscilloscope picture of an rpm sensor.

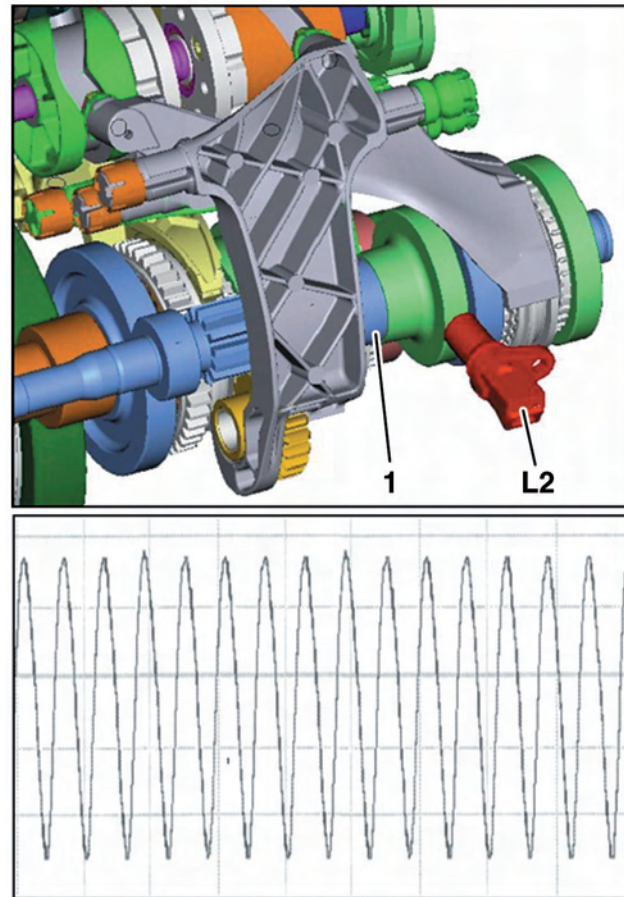

P26.19-2104-00

1 Input shaft
L2 Transmission rpm sensor

Transmission control

Transmission motors 1 and 2 (M17/3 and M17/4)

Location

The transmission motors are located on the transmission housing.

Task

Depending on the shift request from the automated manual transmission control unit (N15/6), the transmission motors adjust the selector drums via a two-stage spur gear transmission. Actuation is pulse-width modulated by two output stages with four electronic switches each. Upon reaching the specified position the transmission motor is braked. It can, if necessary, be actuated with opposing voltage, if an overshoot beyond the specified position is to be prevented or reversed.

Actuation of the transmission motors is monitored by the incremental sensors, which are located on each motor shaft. These detect the rotation angle and rotation direction of the respective transmission motor using the integrated Hall sensors.

The transmission motors are only actuated to execute the shift operations. Once a target position is reached, a pin engages in the locking groove of the selector drum to maintain the selected gear.

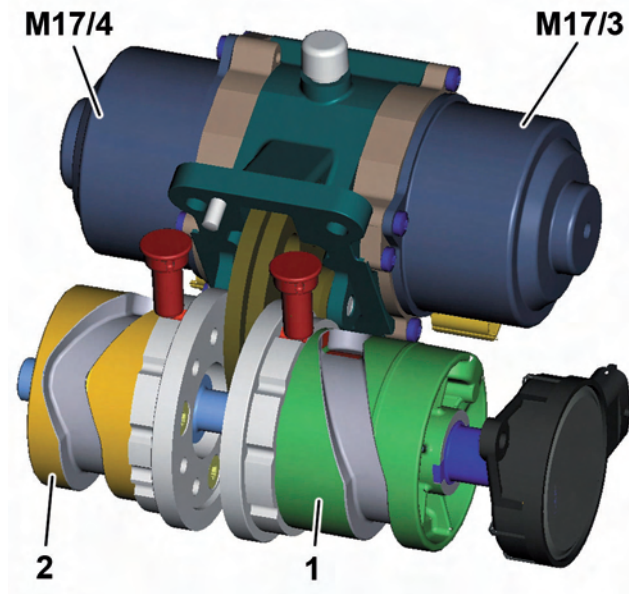

P26.60-2321-00

- | | |
|-------|------------------------------------|
| 1 | Transmission motor 1 selector drum |
| 2 | Transmission motor 2 selector drum |
| M17/3 | Transmission motor 1 |
| M17/4 | Transmission motor 2 |

Automated manual transmission control unit (N15/6)

Location

The automated manual transmission control unit is located in the passenger compartment under the driver seat.

General

The transmission control converts the driver's shift requests into corresponding control signals to the clutch and the 5-speed automated manual transmission.

This is done by relaying the shift signal about the shift request at the electronic selector lever module control unit over a direct line to the automated manual transmission control unit.

The automated manual transmission control unit checks the plausibility of the shift request in relation to the vehicle speed, the load (accelerator pedal position) and the engine speed.

If the plausibility check is passed, the automated manual transmission control unit sends the signal to initiate the selected shift operation to the two actuator motors for the two selector drums and to the clutch motor to open or close the clutch.

Task

The automated manual transmission control unit controls the following functions depending on the input information:

- Engaging first gear at vehicle standstill
- Gear change
- Compulsory upshift just before maximum engine speed is reached
- Compulsory downshift when engine idle speed is approached
- Downshift for kickdown
- Disengaging the gear after 1 s when a door is opened without the service brake or accelerator pedal being actuated
- Crawl function
- Clutch operation
- Monitoring of clutch load

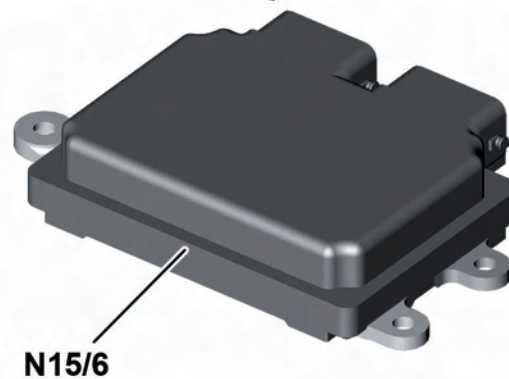

N15/6

P26.19-2145-00

N15/6 Automated manual transmission control unit

The automated manual transmission control unit directly reads the signals from the following components:

- Transmission rpm sensor (L2)
- Transmission motor 1 (M17/3)
- Transmission motor 2 (M17/4)
- Clutch motor (M18)
- Electronic selector lever module control unit (N15/5)
- Park pawl switch (S16/2)

Transmission control

The following components are actuated directly by the automated manual transmission control unit:

- Transmission motor 1 (M17/3)
- Transmission motor 2 (M17/4)
- Clutch motor (M18)

Communication via CAN takes place with the following components:

- Instrument cluster (A1)
- ME-SFI [ME] control unit (N3/10)
- SAM control unit (N10/10)
- Electronic selector lever module control unit (N15/5)
- ESP control unit (N47-5)

Electronic selector lever module control unit (N15/5)

Location

The electronic selector lever module control unit is located in the center console.

Task

The electronic selector lever module control unit records the shift requests of the driver.

The shift positions "N", "R", "+" and "-" are detected by Hall sensors in the electronic selector lever module control unit and are read and evaluated by the electronics in the electronic selector lever module control unit. The signals corresponding to the shift lever positions are transferred to the automated manual transmission control unit.

The release button on the selector lever must be actuated in order to move the selector lever to the following positions:

- From **P** to **R**, **N** or **D**
- From **R** to **P**
- From **N** to **R** or **P**

The transmitter key can only be removed in position 0 if the selector lever is in position **P**.

When the transmitter key is removed, the selector lever is locked in position **P**.

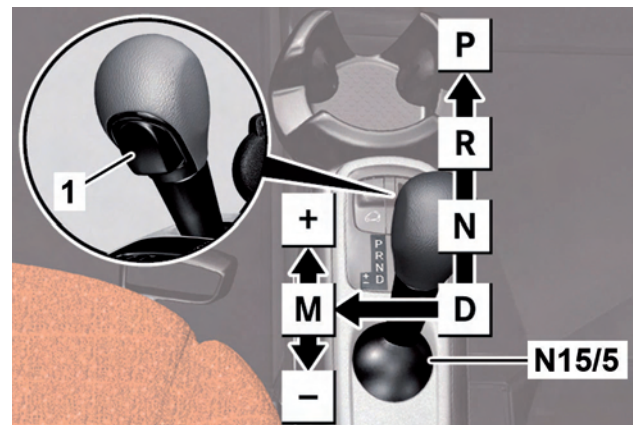

P26.60-2375-00

1 Unlock button

N15/5 Electronic selector lever module control unit

P Park
R Reverse gear
N Neutral position
D Automatic mode
M Manual mode
 + Upshift
 - Downshift

i Note

When reverse gear is requested, the backup light is actuated directly by the electronic selector lever module control unit.

Transmission control

Manual mode

In manual mode (selector lever in position **M**), the gears are shifted either using the selector lever or using the paddle shifts on the steering wheel (SAL).

The gear which is currently selected is displayed on the multifunction display in the instrument cluster. The gear indicator may change to provide gearshift recommendations (arrow up or down). The gearshift recommendations are based on a driving style which optimizes fuel consumption.

Automatic mode

In automatic mode (selector lever in position **D**), the automated manual transmission control unit determines the gear changes. The selected gear range **D** is displayed on the multifunction display in the instrument cluster.

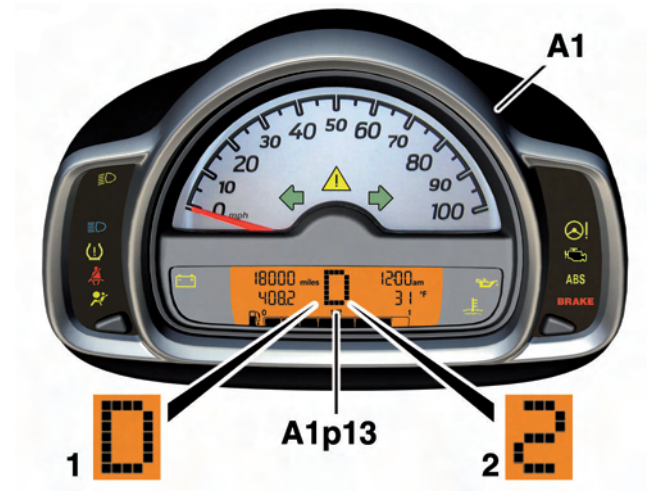

P54.32-5683-00

- 1 Gear range display (automatic mode)
- 2 Gear display (manual mode)

- A1 Instrument cluster
- A1p13 Multifunction display

Transmission control

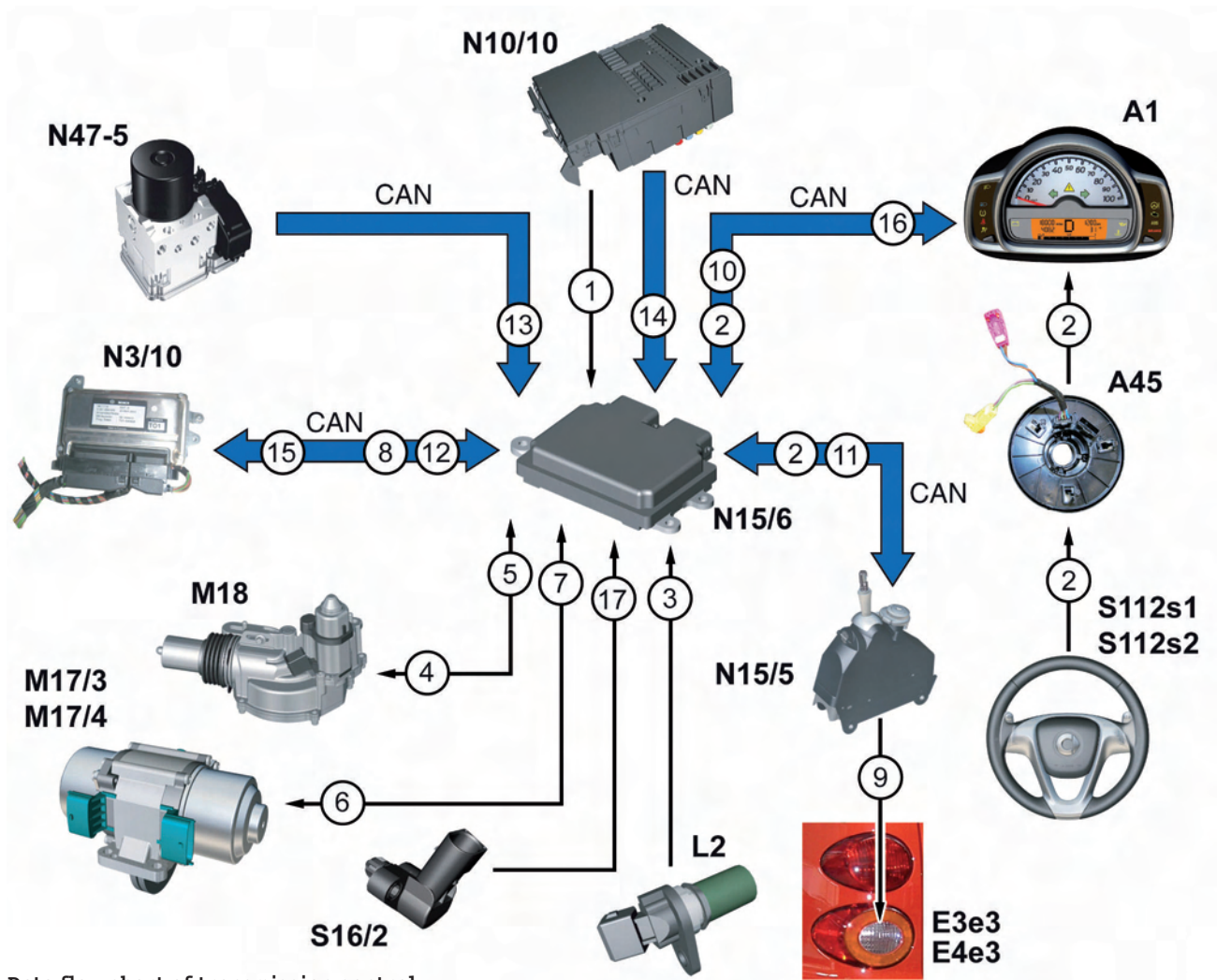

Data flow chart of transmission control

P26.19-2141-00

- | | | | |
|----|----------------------------|--------|---|
| 1 | Circuit status | A1 | Instrument cluster |
| 2 | Shift request | A45 | Fanfare horns and airbag clock spring contact |
| 3 | Transmission speed | E3e3 | Left backup light |
| 4 | Clutch request | E4e3 | Right backup light |
| 5 | Clutch motor status | L2 | Transmission rpm sensor |
| 6 | Gear change request | M17/3 | Transmission motor 1 |
| 7 | Transmission motor status | M17/4 | Transmission motor 2 |
| 8 | Engine speed | M18 | Clutch motor |
| 9 | Backup light actuation | N3/10 | ME-SFI [ME] control unit (gasoline engine) |
| 10 | Vehicle speed | N10/10 | SAM control unit |
| 11 | Shift program selection | N15/5 | Electronic selector lever module control unit |
| 12 | Accelerator pedal position | N15/6 | Automated manual transmission control unit |
| 13 | Brake pedal status | N47-5 | ESP control unit |
| 14 | Door status | S16/2 | Park pawl switch |
| 15 | Engaged gear | S112s1 | Steering wheel gear shifter PLUS (SAL) |
| 16 | Gear indicator actuation | S112s2 | Steering wheel gear shifter MINUS (SAL) |
| 17 | Park pawl status | CAN | Controller Area Network (data bus/CAN bus) |

Park pawl

Mechanical park pawl

In addition to the parking brake, the 5-speed automated manual transmission is equipped with a mechanical park pawl to prevent the vehicle from rolling away. The mechanical park pawl is operated by the electronic selector lever module control unit via a cable.

The status of the park pawl is reported to the automated manual transmission control unit via the park pawl switch (S16/2).

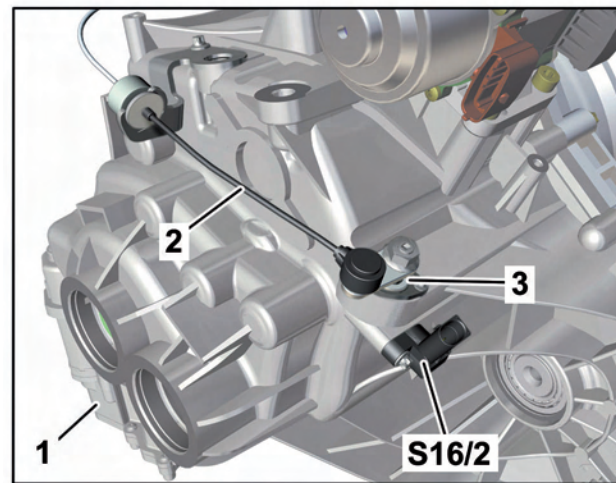
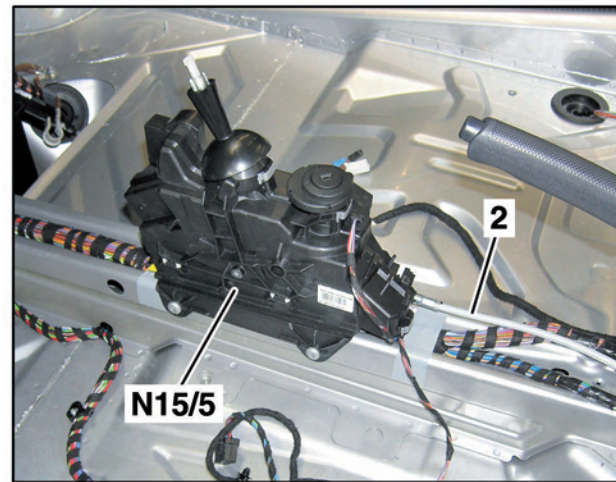

P26.60-2377-00

- 1 *Transmission*
- 2 *Cable*
- 3 *Park pawl*

N15/5 *Electronic selector lever module control unit*
 S16/2 *Park pawl switch*

Clutch

Single-plate dry clutch

A single-plate dry clutch, consisting of clutch plate and pressure plate, is installed on model 451.

An internal computer in the automated manual transmission control unit evaluates the clutch load. If a threshold value is exceeded, the clutch starts to pulse as an overload warning to the driver.

If the overloading continues, e.g. if the car is being held with the clutch on a gradient, the clutch is closed in order to provoke a stall.

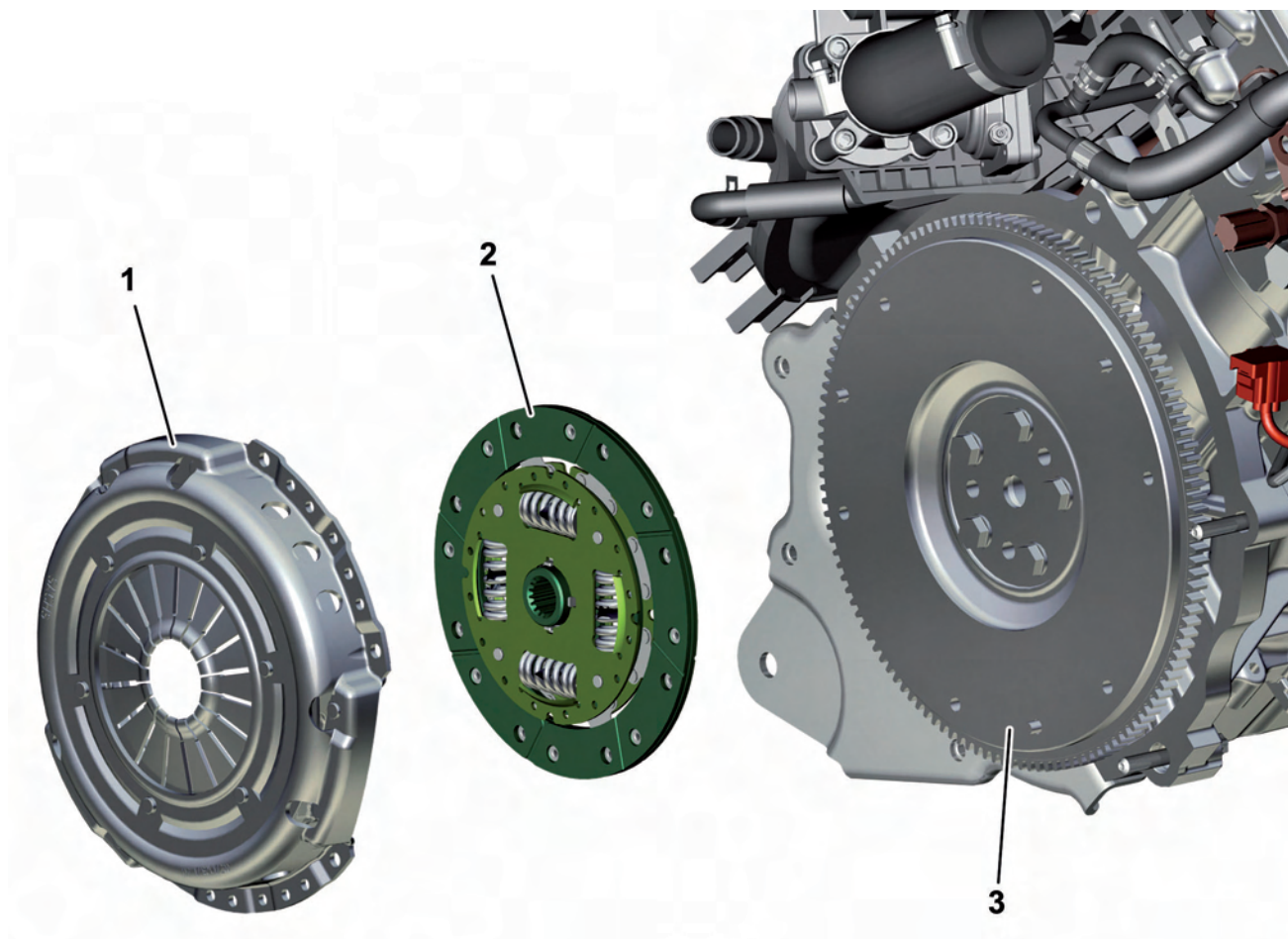

P25.00-2010-00

Single-plate dry clutch

- 1 Pressure plate
- 2 Clutch plate
- 3 Flywheel with starter ring gear

Clutch motor

General

Model 451 is fitted with a 5-speed automated manual transmission. This means that a single-plate dry clutch is installed instead of the torque converter that is usual with conventional automatic transmissions. The single-plate dry clutch is actuated by the clutch motor.

Function

When the automated manual transmission control unit issues a request for a gear change, the clutch motor is actuated at the same time. The electric motor integrated in the clutch motor operates the clutch via the actuating plunger. The power flow is interrupted and the shift operation can be performed.

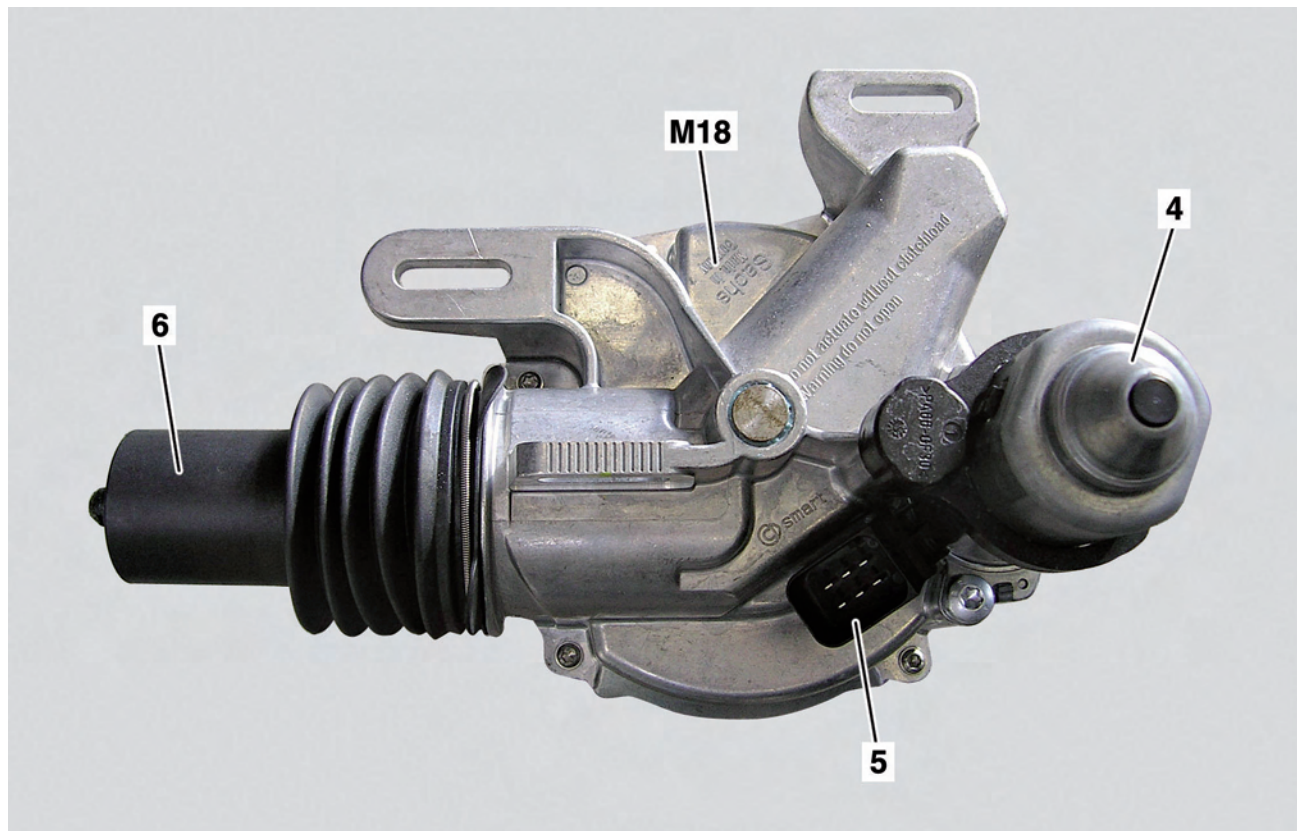

P25.19-2010-00

- 4 Electric motor
- 5 Electric motor connector
- 6 Actuating plunger

M18 Clutch motor

Front axle

Front axle

The front axle has a classic McPherson design.

The supporting ball joint is press-fitted with the transverse control arm forming a single component unit. If repairs are necessary, the supporting ball joint must be replaced complete with the cross-member since a satisfactory press-fit cannot be guaranteed in the repair shop.

The wheel bearing in the steering knuckle is not available separately either because it is pressed into the steering knuckle and can only be ordered as a complete unit with the steering knuckle.

Adjustment capabilities

On the front axle it is only possible to adjust the toe; the camber can only be corrected by utilizing the "play" at the attachment points of the front axle.

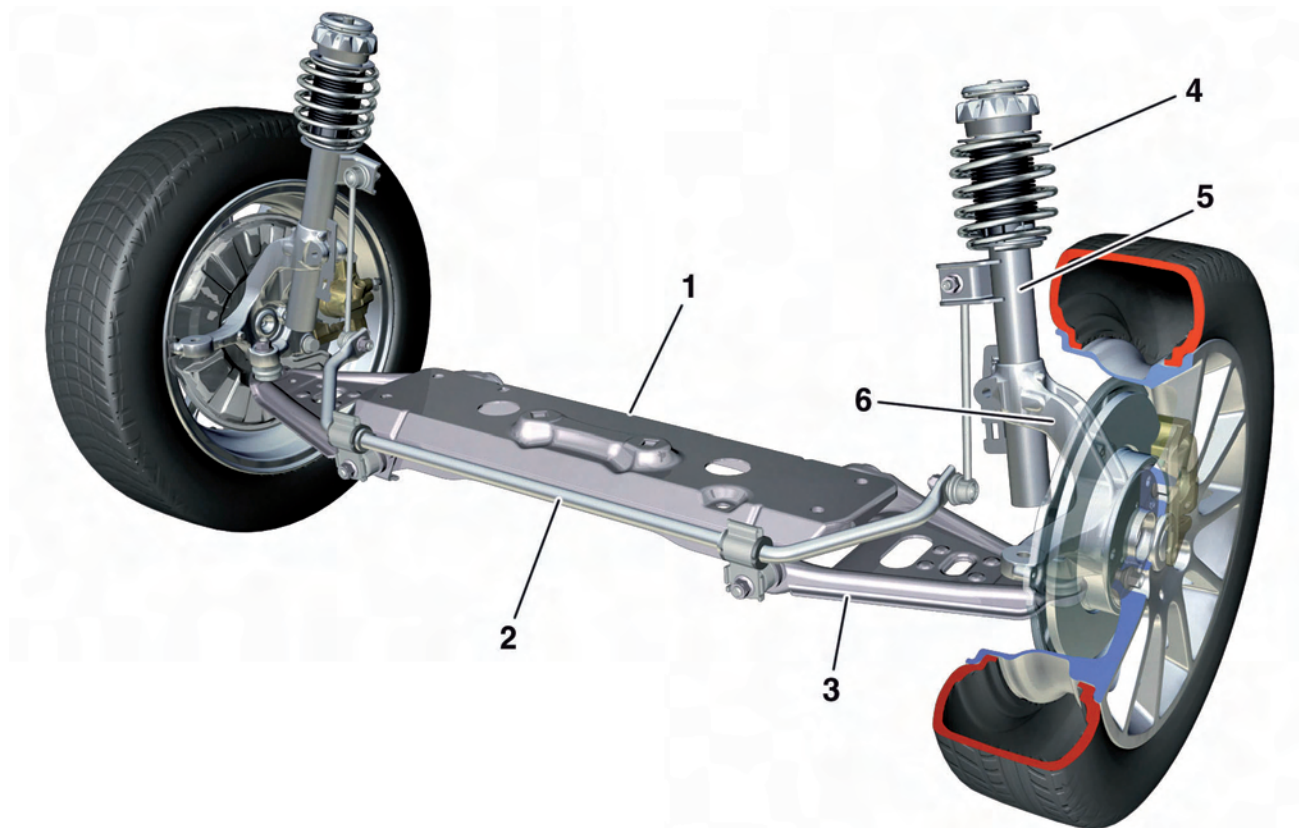

P33.00-2086-00

Front axle - smart fortwo model 451

- | | |
|--|--|
| 1 Front axle crossmember | 4 Coil spring |
| 2 Stabilizer bar | 5 Two-tube shock absorber |
| 3 Transverse control arm with press-fitted supporting ball joint | 6 Wheel carrier, cast iron with pressed-in wheel bearing |

Rear axle with suspension

The rear axle consists of:

- Axle tube
- Frame-type integral support
- Coil springs
- Bar link
- Single-tube shock absorbers
- Center bearing

The frame-type integral support supports the rear wheel drive module. The coil springs are located at the outsides and support the body against rolling movements.

The single-tube shock absorbers are fixed in place at the top with pin bearings.

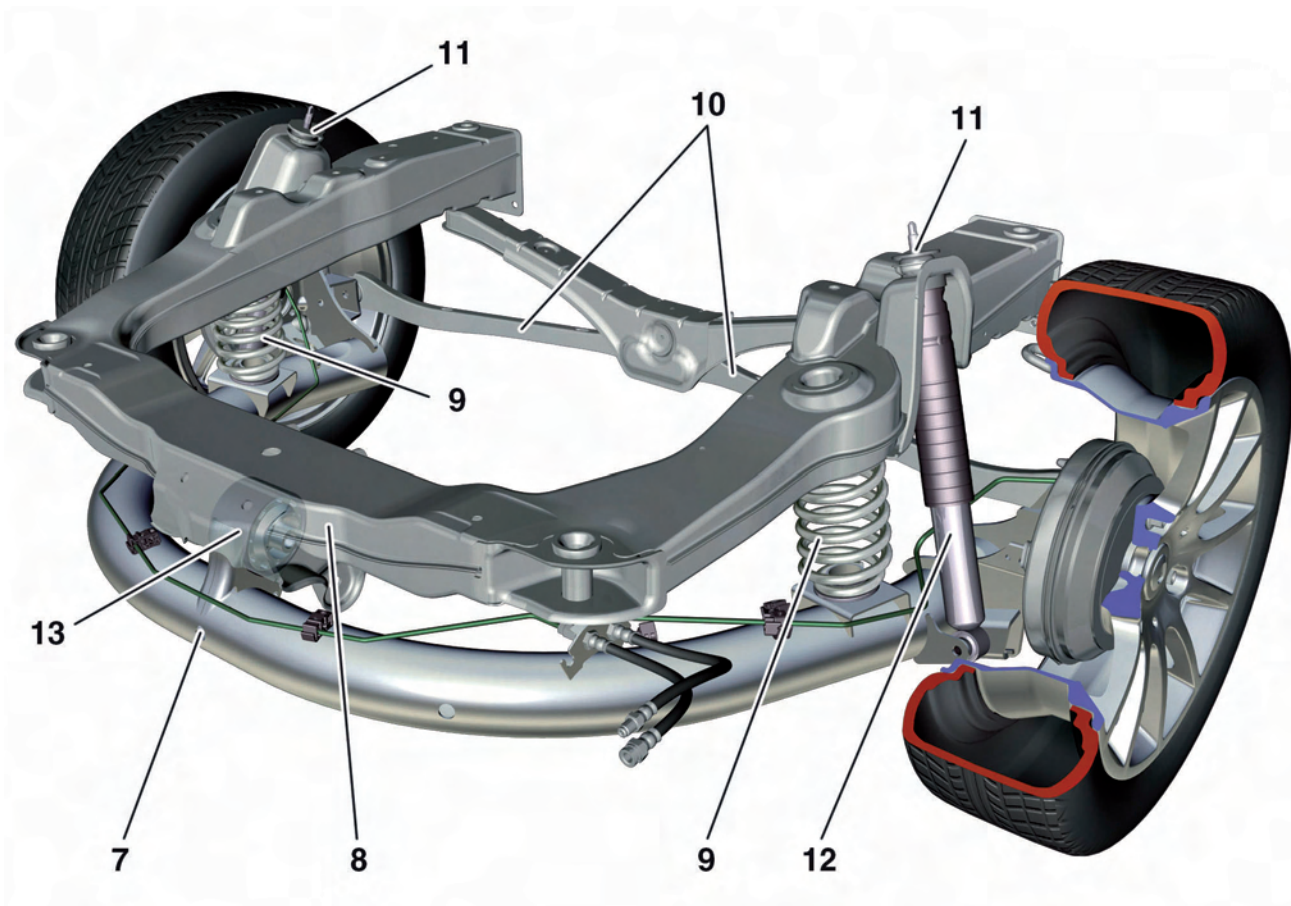

Rear axle - smart fortwo model 451

P35.00-2075-00

- 7 Axle tube
- 8 Frame-type integral support
- 9 Coil spring
- 10 Bar link

- 11 Single-tube shock absorber pin bearing
- 12 Single-tube shock absorber
- 13 Center bearing

Rear module

Lowering the rear module

On model 451, the rear wheel drive module can be lowered.

This shortens removal/installation time for various major assemblies such as the refrigerant compressor, starter, alternator etc., because all the attached parts on the engine and the engine itself can be reached very quickly and with relatively little effort. This shortens repair times and reduces costs while improving customer satisfaction at the same time.



Lowered rear drive module

P35.00-2085-00

Tire pressure monitor

General

The tire pressure monitoring system (TPM [RDK]) monitors the air pressure in the individual tires and improves active safety. A previously stored tire pressure is used as a comparative value. If a relevant loss of pressure occurs, the tire pressure monitor warning lamp in the instrument cluster warns the driver. The tire pressure measuring range is $p = 0$ to 78 psi ($p = 0$ to 5.5 bar).

The TPM [RDK] system has the following subfunctions:

- Tire pressure sensing
- Warning display
- Manual restart

Function requirements

- Circuit 15 ON
- Tire pressure monitor (TPM [RDK]) system functional

Tire pressure sensing

The TPM [RDK] control unit is permanently operational. Each time the CAN wakes up, the control unit performs a re-initialization. While driving, the tire pressure monitoring (TPM [RDK]) system continuously monitors the tire pressure of all rotating wheels (with circuit 15 OFF for a further $t = 19$ min). When the vehicle is parked for $t > 19$ min, on-board wheel detection and axle assignment must first be completed via the TPM [RDK] wheel sensors. While driving, the TPM [RDK] wheel sensors transmit data telegrams every 60 seconds.

These data telegrams contain the following information:

- Tire pressure
- Tire air temperature
- Individual serial number
- Status information
(manufacturer, direction of rotation, operating mode etc.)

In addition the TPM [RDK] control unit takes into account the outside temperature and the vehicle speed for the tire pressure determination. These data are provided via CAN by the instrument cluster.

Warning indicator

A warning is issued when a relevant loss of pressure has been detected in at least one of the tires. The warning is issued in the instrument cluster via the tire pressure monitor warning lamp, but the specific tire where pressure loss has occurred is not specified.

Manual restart

The tire pressure to be monitored can be reset via the TPM [RDK] switch on the cockpit switch panel. When the TPM [RDK] switch is pressed, the current tire pressure is stored in the memory of the TPM [RDK] control unit and is then used as the reference pressure, as long as it is within the permissible limits.

The tire pressure monitor warning lamp in the instrument cluster flashes to indicate that a manual restart has taken place.

i Note

A manual restart must be performed each time the tire inflation pressure is changed and when a wheel, wheel sensor or the TPM [RDK] control unit is replaced.

If the nut on the valve element of a wheel sensor is loosened, all components of the valve element must be replaced.

See the Workshop Information System (WIS) for further instructions and information.

Tire pressure monitor

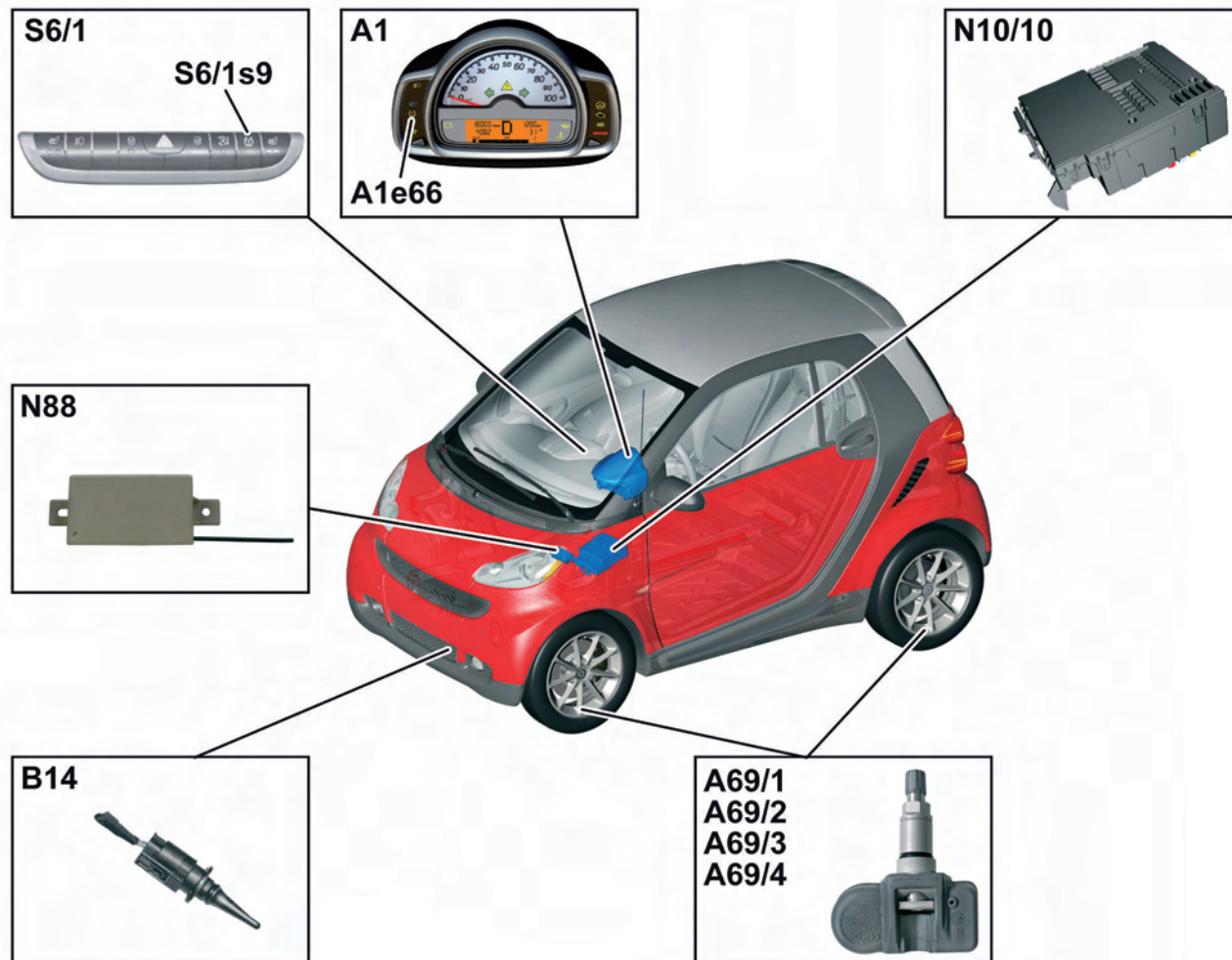

P40.15-2424-00

Location of TPM [RDK] components

<i>A1</i>	<i>Instrument cluster</i>	<i>B14</i>	<i>Outside temperature display temperature sensor</i>
<i>A1e66</i>	<i>Tire pressure monitor warning lamp</i>	<i>N10/10</i>	<i>SAM control unit</i>
<i>A69/1</i>	<i>Left front TPM [RDK] wheel sensor</i>	<i>N88</i>	<i>TPM [RDK] control unit</i>
<i>A69/2</i>	<i>Right front TPM [RDK] wheel sensor</i>	<i>S6/1</i>	<i>Cockpit switch group</i>
<i>A69/3</i>	<i>Left rear TPM [RDK] wheel sensor</i>	<i>S6/1s9</i>	<i>TPM [RDK] switch</i>
<i>A69/4</i>	<i>Right rear TPM [RDK] wheel sensor</i>		

Task

The task of the brake system is to brake the vehicle or hold it at a standstill.

The system includes the service brake, which brakes the vehicle while it is being driven, and the parking brake, which secures the vehicle when it is at a standstill.

Components of the parking brake

- Hand brake lever with hand brake cables
- Parking brake mechanism integrated into rear drum brake

Function of parking brake

When the handbrake lever is actuated, a relay lever is actuated at the rear brake shoes of the left and right drum brakes via the handbrake cables. This presses the brake shoes of the drum brakes against the insides of the brake drums to build up the required brake force.

Components of the service brake

- Disk brakes with brake calipers on front axle
- Drum brakes with aluminum wheel brake cylinders on rear axle
- Brake fluid reservoir
- Brake lines and brake hoses
- Brake pedal module
- ESP unit, consisting of ESP control unit and ESP hydraulic unit

Function of service brake

The service brake is a hydraulic 2-circuit brake system with TT (front/rear) split.

The force applied to the brake pedal is transferred to the brake booster via a linkage. The brake booster multiplies this forces and uses it to pressurize the master brake cylinder. The brake pressure is built up via the master brake cylinder.

The brake force is distributed to the disk brakes and drum brakes by the ESP unit via the integrated antilock brake system (ABS) and the electronic brake force distribution (EBD) system.

Brakes

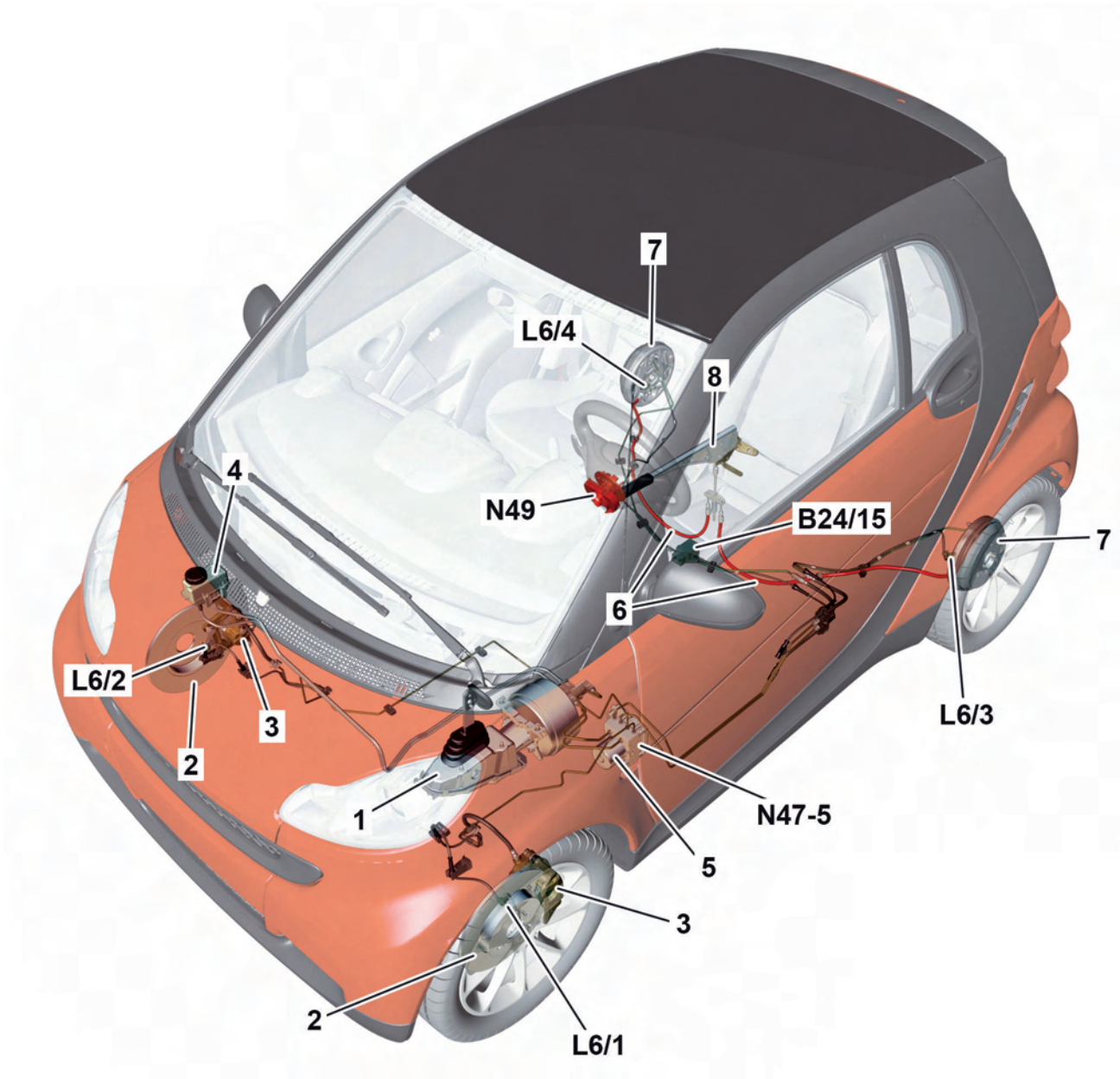

P40.10-2711-00

Brake system

- 1 Brake pedal module
- 2 Brake disk
- 3 Brake caliper
- 4 Expansion reservoir
- 5 ESP unit
- 6 Hand brake cables
- 7 Drum brake (consisting of: anchor plate, wheel brake cylinder, brake shoe, springs and brake drum)
- 8 Hand brake lever

- B24/15 Yaw rate, lateral and longitudinal acceleration sensor
- L6/1 Left front rpm sensor
- L6/2 Right front rpm sensor
- L6/3 Left rear rpm sensor
- L6/4 Right rear rpm sensor
- N47-5 ESP control unit
- N49 Steering angle sensor

Brake pedal module

The brake pedal module is located on the underfloor and consists of the following assemblies:

- Pedals
- Carrier
- Brake booster
- Master brake cylinder

Pedals

The pedals consist of:

- Pedal head
- Perforated boot
- Pedal assembly seal
- Housing
- Linkage rod
- Brake pedal module cover
- Seal for brake pedal module cover
- Brake light switch

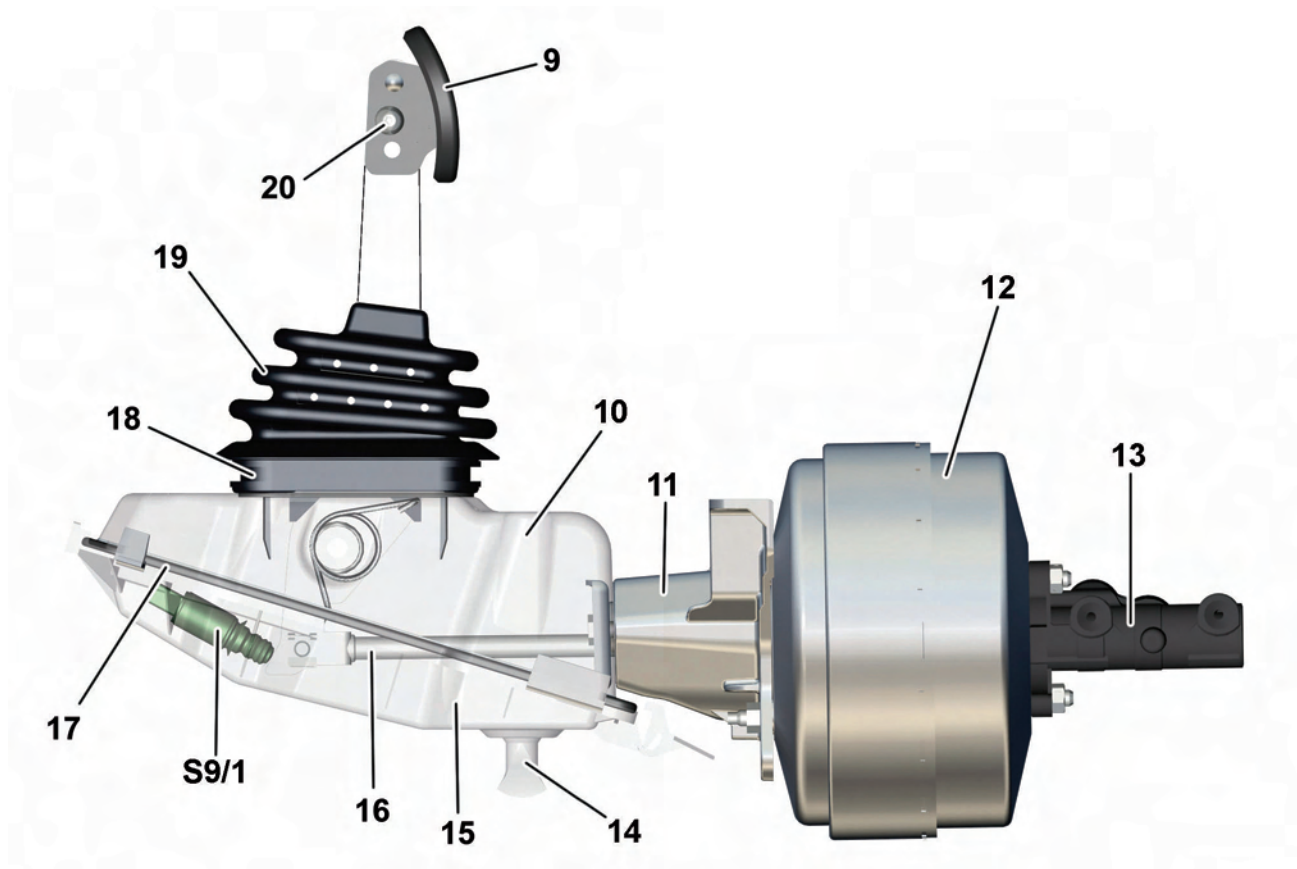

P42.10-2712-00

Brake pedal module

- | | | | |
|----|--------------------------|------|---------------------|
| 9 | Pedal head | 16 | Linkage |
| 10 | Housing | 17 | Seal |
| 11 | Carrier | 18 | Pedal assembly seal |
| 12 | Brake booster | 19 | Perforated boot |
| 13 | Master brake cylinder | 20 | Bolt |
| 14 | Grommet | S9/1 | Brake light switch |
| 15 | Brake pedal module cover | | |

Brakes

Pedals

The seals and the boot on the pedals may not be damaged otherwise moisture can penetrate into the interior compartment.

To ensure that the pedals remain leaktight, the brake pedal module cover must be replaced each time the pedals are disassembled.

Brake light switch

The brake light switch in the pedal assembly is only accessible after the brake pedal module cover has been removed.

The brake light switch is actuated via the linkage in the pedal assembly when the brake is actuated. The signal from the brake light switch is read by the ESP control unit.

The free travel of the brake light switch must be correctly adjusted to ensure that the brake light switch operates properly.

Brake lines

All brake lines may only be retightened twice at the most when work is performed on the vehicle. If a threaded connection on a brake line is loosened and then retightened, this must be documented. The respective threaded connection must be marked in color with a suitable safety paint.

The following color codings are specified:

- First retightening: yellow marking
- Second retightening: red marking

If the respective threaded connection is loosened again after being retightened for a second time, the detached brake line must be replaced. This also applies if it is not possible to trace how often the threaded connection has previously been loosened.

Brake system bleeding

Whereas the brake fluid can be replaced by one person, the hydraulic brake system can only be bled by two people working together. When bleeding the primary and secondary circuit, one person must build up the pressure required by the brake fluid changer by repeatedly actuating the brake pedal. The second person is needed to:

- Actuate the ESP hydraulic unit via diagnosis at the same time and perform the bleeding procedure when bleeding the primary circuit
- Perform the bleeding procedure when bleeding the secondary circuit

i Note

To ensure that the brake system is not damaged, the filling pressure on the brake fluid changer may be set to max. 2.8 psi (2 bar).

Basic adjustment of brake shoes

After brake shoes are replaced or removed/installed, basic adjustment of the drum brake must be performed. To do so, the brake shoes are measured and adjusted using the slack adjuster.

Drum brake adjustment

Manual adjustment of the clearance between brake shoe and brake drum is not permissible. Adjustment may only be performed via the automatic slack adjuster of the brake shoes to prevent grinding or locking of the drum brake.

i Note

See the Workshop Information System (WIS) for the exact procedure for repairing the brake system and for the relevant safety information.



ESP system

The latest ESP system (version 8.1) is installed next to the brake pedal module on the underfloor and features the following functions:

- ABS
- ASR
- HBA
- EBD
- ESP
- EBR
- Start-off assist

Antilock brake system (ABS)

Prevents individual wheels from locking up by regulating the brake pressure at the relevant wheel brakes. The vehicle remains steerable, enabling the driver to take evasive action himself to avoid sudden obstacles during emergency braking.

Acceleration skid control (ASR)

Prevents the drive wheels from spinning by intervening in the engine management and brake pressure regulation. ASR provides good traction and improves vehicle stability and steerability when moving off and accelerating.

Hydraulic brake assist (HBA)

Regulates the pressure buildup in the brake system in relation to the vehicle speed and the actuation speed of the brake pedal. When emergency braking is detected by means of characteristics defined beforehand, the ESP control unit actuates the return flow pump that is integrated in the hydraulic unit. The maximum brake pressure is built up.

Electronic brake force distribution (EBD)

Regulates the brake pressure at the rear wheels in the partial braking range in order to improve the stability of the vehicle and the braking effect.

Electronic stability program (ESP)

Minimizes oversteer or understeer by means of specific intervention by the brake system at each wheel on the front and rear axles. There may also be intervention in the engine and transmission control systems if necessary.

Engine braking regulation (EBR)

Reduces slip of the drive wheels in deceleration mode and thereby improves directional stability and road adhesion.

Start-off assist

Maintains the brake pressure for approx. 0.7 s after the brake pedal is released to facilitate start-off on uphill slopes.

Rpm sensors

The rpm sensors are active sensors, i.e. they must be connected to a voltage source in order to operate. They deliver a signal with an rpm-independent, constant amplitude, and utilize the Hall effect to detect the rpm signal.

Yaw rate, lateral and longitudinal acceleration sensor

The yaw rate, lateral and longitudinal acceleration sensor is a combined sensor of micromechanical design. It registers the yaw rate (yaw angle velocity) of the vehicle about the vertical axis, the longitudinal acceleration and the lateral acceleration.

i Note

In the event of an emergency stop in which the vehicle is braked to a standstill from a speed in excess of 43 mph (70 km/h), the SAM control unit automatically activates the hazard warning system. Deactivation of the hazard warning function occurs automatically when the vehicle speed is detected to have risen above 6 mph (10 km/h) or manually by actuation of the hazard warning system switch.

Brakes

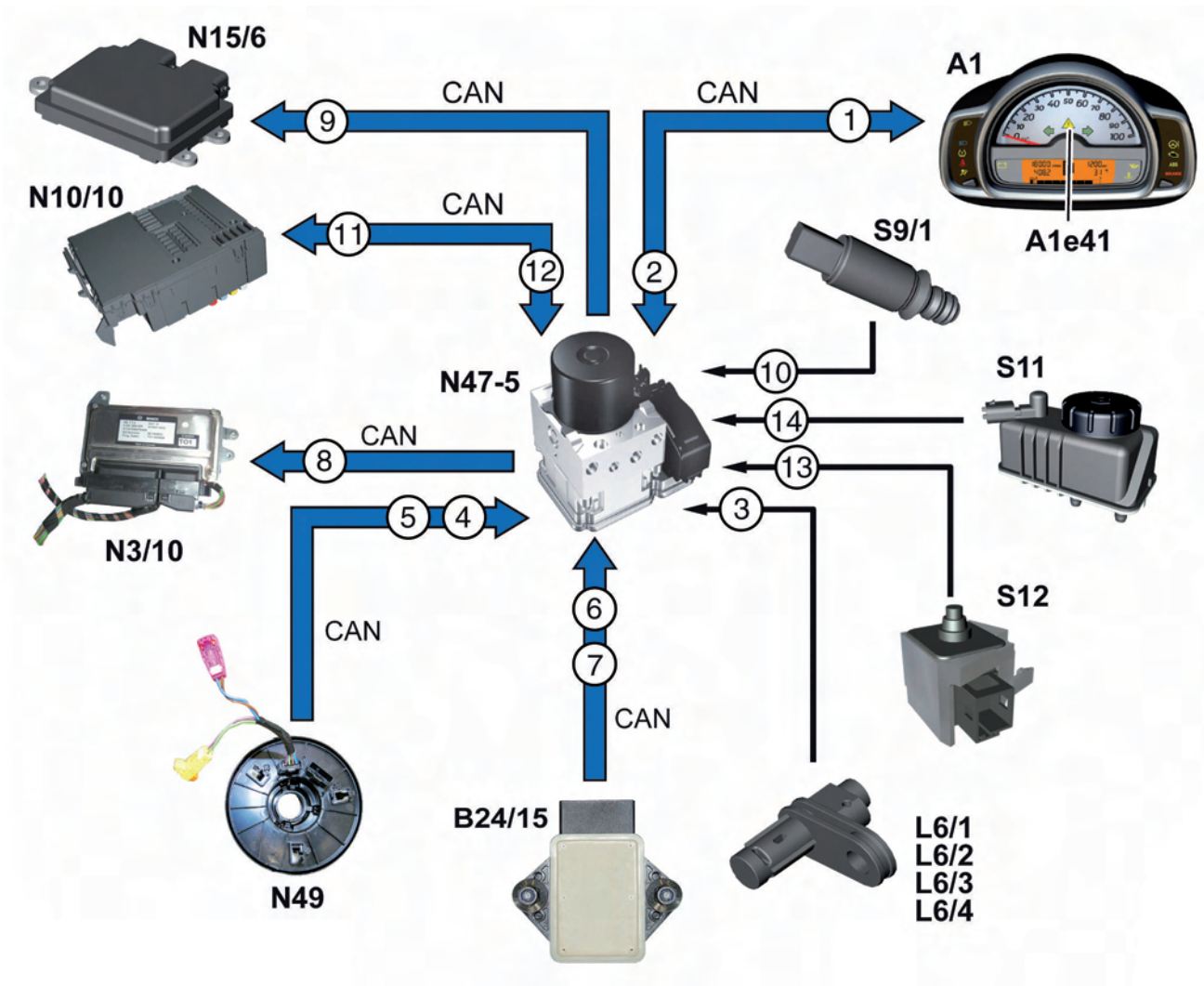

P42.45-2662-00

Data flow chart of Electronic Stability Program ESP

1	ESP/ABS/ASR status	B24/15	Yaw rate, lateral and longitudinal acceleration sensor
2	ESP/ABS/ASR display status	L6/1	Left front rpm sensor
3	Wheel speed signal	L6/2	Right front rpm sensor
4	Steering angle	L6/3	Left rear rpm sensor
5	Steering rate	L6/4	Right rear rpm sensor
6	Lateral and longitudinal acceleration	N3/10	ME-SFI [ME] control unit
7	Yaw rate	N10/10	SAM control unit
8	Engine torque control	N15/6	Automated manual transmission control unit
9	Transmission control intervention	N47-5	ESP control unit
10	Brake pedal status	N49	Steering angle sensor
11	Emergency stop reference speed	S9/1	Brake light switch
12	Driver door closed status	S11	Brake fluid indicator switch
13	Handbrake status	S12	Parking brake indicator switch
14	Brake fluid status		
A1	Instrument cluster		
A1e41	ESP warning lamp		
		CAN	Controller Area Network (data bus/CAN bus)

Rack-and-pinion steering

The smart fortwo features rack-and-pinion steering as standard. The steering ratio is 22:1.

Electric power steering EPS (special equipment)

Electric Power Steering (EPS) is available as special equipment. The steering ratio is 21:1.

The tasks of the EPS system are as follows:

- Power assistance with Servotronic
- Adaptation of the steering forces
- Active steering centering

General

Electric Power Steering (EPS) is a direct steering system with integral speed-dependent power assistance and active steering centering. This ensures that steering wheel forces remain low when the vehicle is being maneuvered.

An electromechanical system offers the following advantages compared to a conventional hydraulic power steering system:

- Less weight and smaller installation space
- Greater degree of freedom to adjust the steering assistance
- Reduced fuel consumption.

EPS operates without hydraulic components such as pumps, reservoirs, coolers, lines and hydraulic fluid, and is therefore a dry, environmentally compatible system.

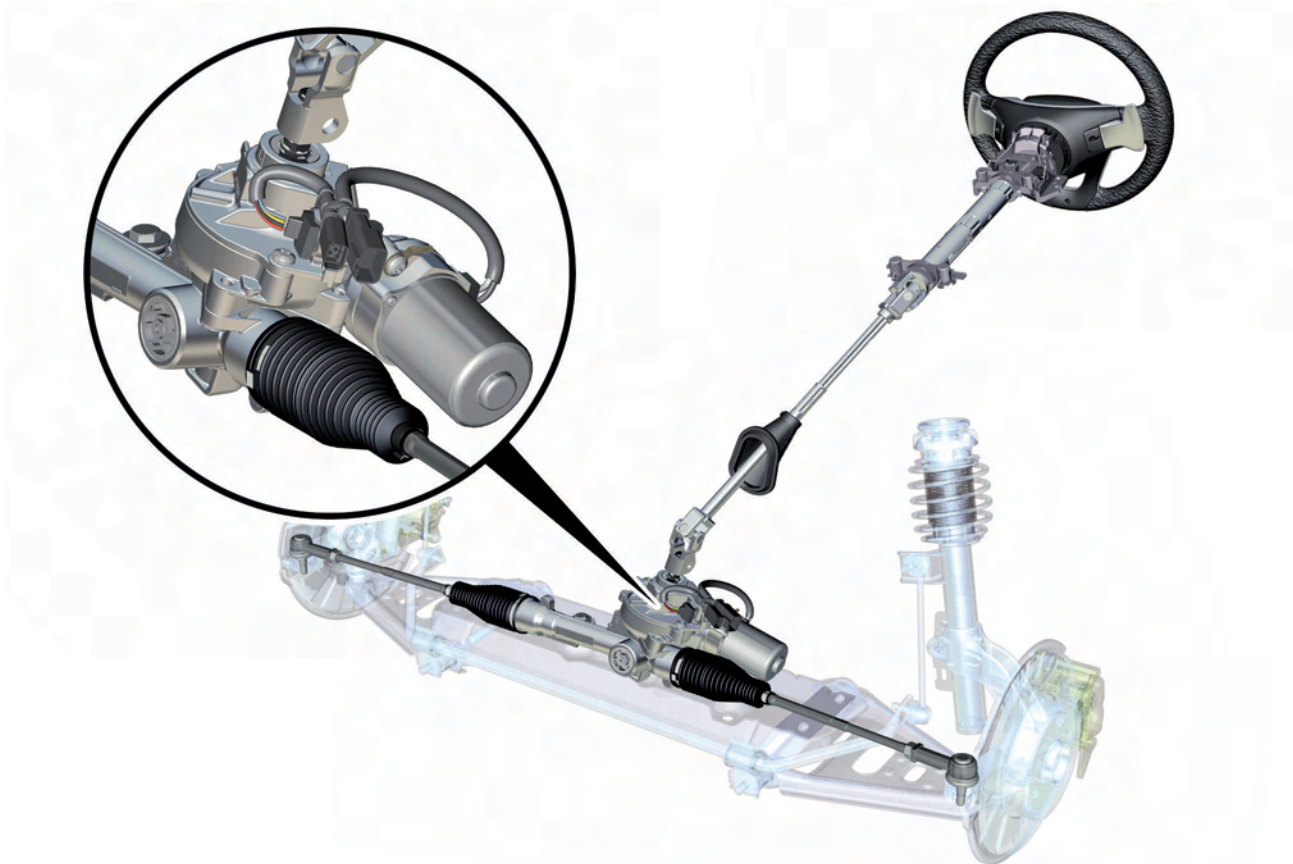

Electric power steering EPS

P46.10-2935-00

Steering

Design

The main components of the electric power steering (EPS) system are the power steering motor, a DC brush-type electric motor with maximum 35 Ampere power consumption and the power steering control unit.

The power steering control unit communicates via the CAN data bus and is located in the vehicle interior on the left of the firewall.

The rack-and-pinion mechanical components for the electric power steering (EPS) are accommodated in a steering housing made of diecast aluminum, to which the power steering motor is also flange-mounted.

To provide steering assistance, the steering gear pinion shaft transmits the rotational movement of the steering gear input shaft to the teeth of the toothed rack. The power steering motor transmits force for steering assistance to the spur tothing of the hyperbolic gear via a worm shaft. The hyperbolic gear is fixed to the pinion of the steering gear pinion shaft. The power steering torque sensor is located in the steering gear housing between the steering gear input shaft and hyperbolic gear.

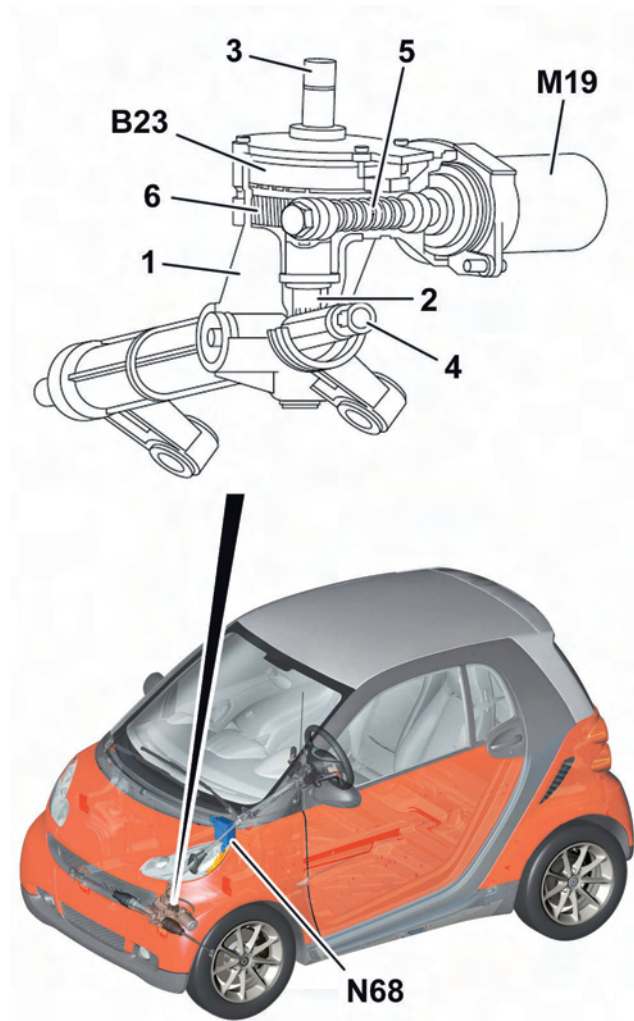

P46.10-2933-00

Components of the electric power steering (EPS)

1	Steering gear housing
2	Steering gear pinion shaft
3	Steering gear input shaft
4	Toothed rack
5	Worm shaft
6	Hyperbolic gear
B23	Power steering torque sensor
M19	Power steering motor
N68	Steering assist control unit

Function

Function requirement

Steering assistance is activated after engine start and at a minimum engine speed of 500 rpm.

Steering power assistance

As the driver turns the steering wheel, a steering torque is produced at the drag link which is registered by the power steering torque sensor and forwarded to the power steering control unit.

The steering torque is used as an actuating variable for the electric assistance force. It is derived from the rotation of the torsion bar, which is located between the steering gear input shaft and steering gear pinion shaft on the same axis.

The power steering torque sensor is located around the torsion bar. This determines the torque over a range of +/- 8.1 lb-ft (11 Nm) and at a resolution of 0.037 lb-ft (0.05 Nm).

The power steering control unit uses the steering torque measurement to determine the level of torque that needs to be provided to supplement the steering force.

Based on this information and depending on the vehicle speed signal from the ESP control unit and the engine speed signal from the ME-SFI [ME] control unit, the power steering control unit determines the current requirement of the power steering motor as per the programmed characteristic field.

The power steering motor transmits the appropriate supplementary steering torque to the face of the hyperbolic gear via the worm shaft.

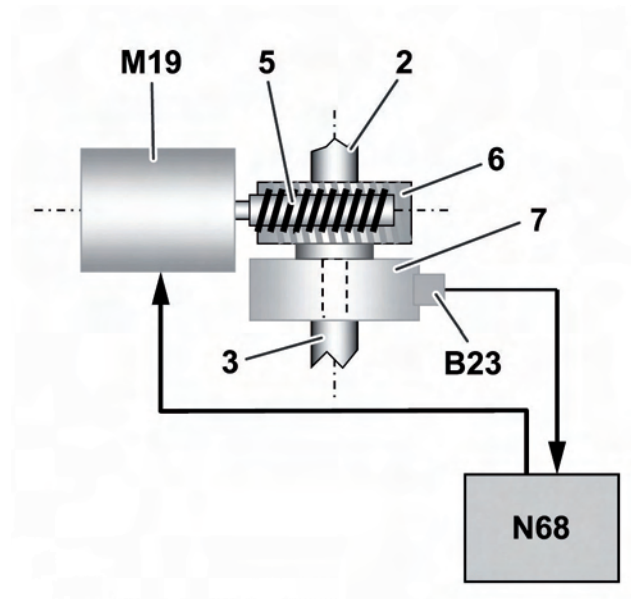

P46.10-2934-00

Steering torque of the electric power steering (EPS)

2	<i>Steering gear pinion shaft</i>
3	<i>Steering gear input shaft</i>
5	<i>Worm shaft</i>
6	<i>Hyperbolic gear</i>
7	<i>Torsion bar</i>
B23	<i>Power steering torque sensor</i>
M19	<i>Power steering motor</i>
N68	<i>Steering assist control unit</i>

Steering

Steering centering

This function returns the steering to the center position once the driver stops applying steering torque. The power steering motor is actuated accordingly by the power steering control unit.

"Active center feeling" function

When the steering wheel is registered in the center position and there are no steering movements, the power steering motor is energized by the steering assist control unit so that a sufficient torque is produced to hold the steering in the straightahead position. This actuation conveys an improved steering center feel to the driver. The system is continuously calibrated and learns the center position automatically. The long-term calibration is performed via the ESP wheel sensor system.

Limp-home function

The steering assist control unit constantly checks all the input signals for plausibility. In the case of a faulty component the steering, power assistance is shut down and a fault is stored in the steering assist control unit. The steering then continues to function as a conventional rack-and-pinion steering.

i Note

If the electric steering suffers a function failure, the electric steering indicator lamp in the instrument cluster lights up to indicate this.

To comply with EMC requirements, the energy line from the power steering control unit to the power steering motor is 85 % shielded against external influences.

The power steering control unit is a CAN bus subscriber in the overall network. The vehicle speed, the steering angle and other data are read in over CAN.

i Note

The steering power assistance is at a maximum at low speeds and when the vehicle is stationary and decreases as the vehicle speed increases. Once the vehicle stops and the engine is switched off, the steering power assistance is deactivated in stages after approx. 3 s.



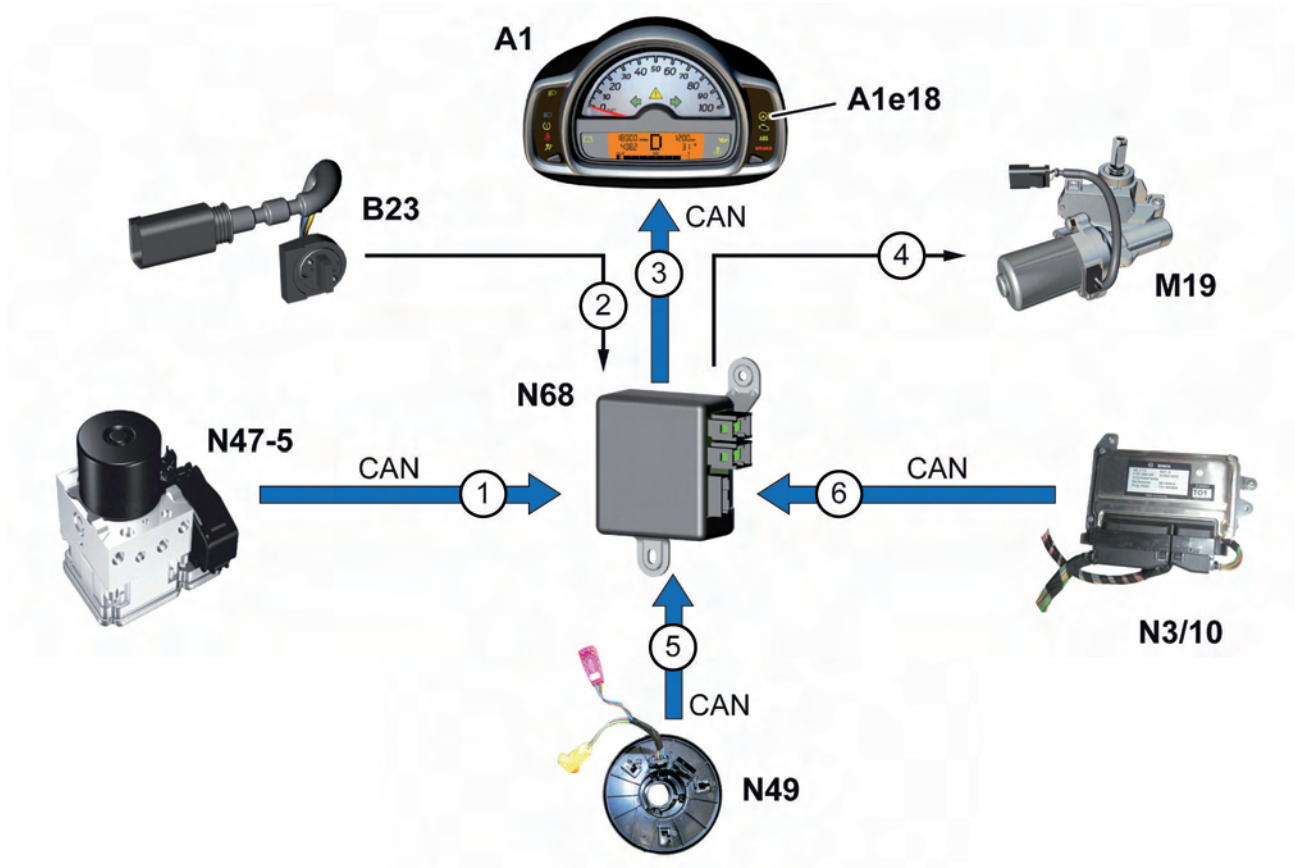

Data flow chart of electric power steering EPS

P46.35-2034-00

- 1 Vehicle speed
- 2 Steering torque
- 3 Warning and fault message output
- 4 Power steering motor actuation
- 5 Steering angle, steering rate
- 6 Engine speed

- A1 Instrument cluster
- A1e18 Electric steering indicator lamp
- B23 Power steering torque sensor
- M19 Power steering motor
- N3/10 ME-SFI [ME] control unit
- N47-5 ESP control unit
- N49 Steering angle sensor
- N68 Steering assist control unit
- CAN Controller Area Network (data bus/CAN bus)

Steering

Steering wheel

Two steering wheel variants are available for model series 451.

Variants

- Leather two-spoke steering wheel of dia. 14.6 in (370 mm) as standard equipment on the pure
- Three-spoke sport steering wheel with integrated paddle shift of dia. 13.8 in (350 mm) as standard equipment on the passion

Paddle shifts on steering wheel

In vehicles that are fitted with a three-spoke sport steering wheel, the paddle shifts on each side of the steering wheel can be used to shift up and down through the gears. It is therefore possible to select a gear on the steering wheel as well as via the gear selector lever.

The left-hand paddle shift is used to downshift and the right-hand paddle shift is for upshifts.

The gear which is currently engaged is displayed on the multifunction display in the instrument cluster.



Two-spoke steering wheel

P46.10-2839-00



Three-spoke sport steering wheel with paddle shifts

P46.10-2840-00



Steering wheel removal and installation

The following components of the steering wheel are replaceable:

- Contact unit with steering angle sensor
- Airbag module
- Paddle shifts (three-spoke sport steering wheel only)

The steering wheel must be detached first before replacing or removing/installing any of the above components.

Care must be taken to ensure that the front wheels are in the straightahead position, the battery is disconnected and the handbrake is applied before the steering wheel is removed.

The exact procedure for removal/installation of the steering wheel and its components is described in the Workshop Information System (WIS).

i Note

All control units must be de-energized before the steering wheel is removed. For this reason, at least 15 minutes must elapse after the battery is disconnected before it is removed.

i Note

Care must be taken to ensure that the turn signal is not set when removing/installing the steering wheel otherwise the trigger tab may be damaged.

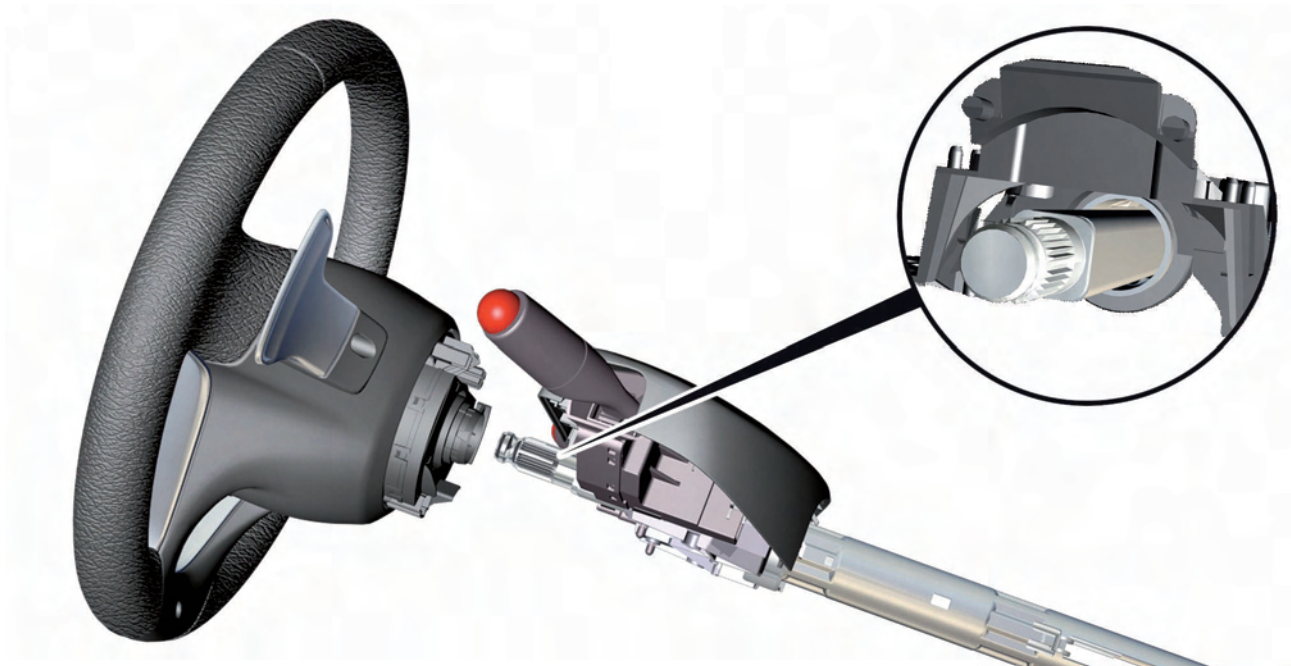

P46.10-2841-00

Interior

Interior design

The interior compartment has a classic look while still displaying modern, typical smart features. This well-balanced overall concept helps the smart fortwo create an exclusive overall impression with high perceived quality.

This is helped by the lines of the instrument panel, the door linings and the seats shaped to match. The harmonized color scheme of the interior also gives a positive impression in combination with the passenger compartment as a whole.



Shown on the smart coupé pure

P68.00-5039-00

Instrument panel

For the design of the instrument panel, particular emphasis was placed on the following criteria:

- Ergonomics
- Clear layout
- Passenger safety

The instrument panel is designed with straight lines and equipped with airbags and a full length knee bolster to improve passenger protection.

Two additional instruments (tachometer and clock) are available as special equipment (SA) and are positioned above the center console. The air vents on the instrument panel have a cylindrical shape.



Shown on the smart coupé passion

P68.10-3852-00

Interior

Instrument cluster

In the center of the instrument cluster is the speedometer scale with the multifunction display underneath.

On each side is a strip with indicators and warning displays, as well as the control buttons for the multifunction display.

The task of the instrument cluster is to provide the driver with information about the various operating states and to provide acoustic or visual warnings in the event of critical operating conditions. It is the display unit for the vehicle speed and for other systems. In addition, the instrument cluster computes the maintenance intervals and shows them in the multifunction display.

The instrument cluster is a device on the data bus/CAN bus in the overall network. Most of the signals are transmitted or received over CAN. The following signals are supplied to the instrument cluster over direct lines:

- Signal from outside temperature indicator temperature sensor
- Signal from "Fanfare horns and airbag clock spring contact" (only on variant with SAL).

The vehicle speed is displayed by an electronic speedometer that is driven by a stepper motor. The ESP control unit reads the information for the speed display from the wheel speed sensors in the form of signals, and forwards it over CAN to the instrument cluster. The instrument cluster processes the incoming signals and uses them to calculate the vehicle speed and distance traveled.

Multifunction display

The task of the multifunction display is to provide the driver with information about variable changes in the vehicle, the ambient conditions and the road.

The variable displays include:

- Outside temperature
- Main odometer
- Trip odometer
- Gear indicator (in manual mode)
- Automatic transmission indicator (in automatic mode)
- Fuel reserve indicator (US gal)
- Maintenance interval display with symbol
- Fuel level and reserve indicator
- Clock



Multifunction display

P54.32-5677-00

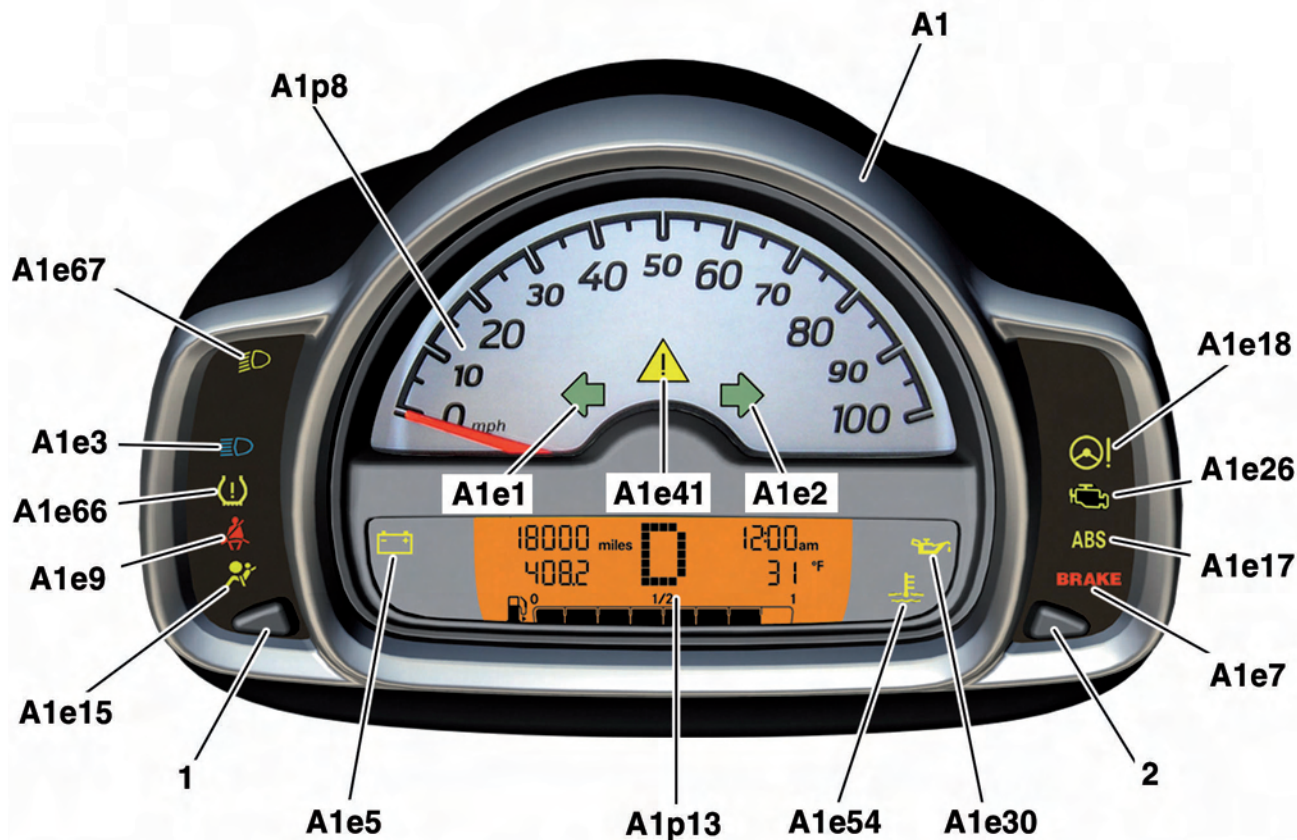

P54.30-9683-00

Instrument cluster

- | | | | |
|------|---|-------|------------------------------------|
| 1 | Left button, select multiple display / set clock | A1e9 | Seat belt warning lamp |
| 2 | Right button, instrument illumination / set clock | A1e15 | Airbag indicator and warning lamp |
| A1 | Instrument cluster | A1e17 | ABS indicator lamp |
| A1e1 | Left turn signal indicator lamp | A1e18 | Electric steering indicator lamp |
| A1e2 | Right turn signal indicator lamp | A1e26 | CHECK ENGINE indicator lamp |
| A1e3 | High beam indicator lamp | A1e30 | Oil pressure warning lamp |
| A1e5 | Alternator charge monitoring and warning lamp | A1e41 | ESP warning lamp |
| A1e7 | Brake fluid and parking brake warning lamp | A1e54 | Coolant temperature warning lamp |
| | | A1e66 | Tire pressure monitor warning lamp |
| | | A1e67 | Low beam indicator lamp |
| | | A1p8 | Electronic speedometer |
| | | A1p13 | Multifunction display |

Doors/flaps

Side doors

The doors of the new smart fortwo follow the typical smart brand construction principle with a metal carrier part and the plastic CBS door paneling. The doors of the smart coupé and the smart cabrio are identical.

The triangular windows located above each door handle are stationary windows held in place by bolts.

Crash requirements

The door support structure in model 451 is made of steel. In addition, panels and sections of high-strength steel are used at strategically important points. This is the case, for example, with the diagonal struts and the side window slot frames.

In combination with the cockpit crossmember, this makes the passenger compartment highly resistant to side impacts in this section of the vehicle.

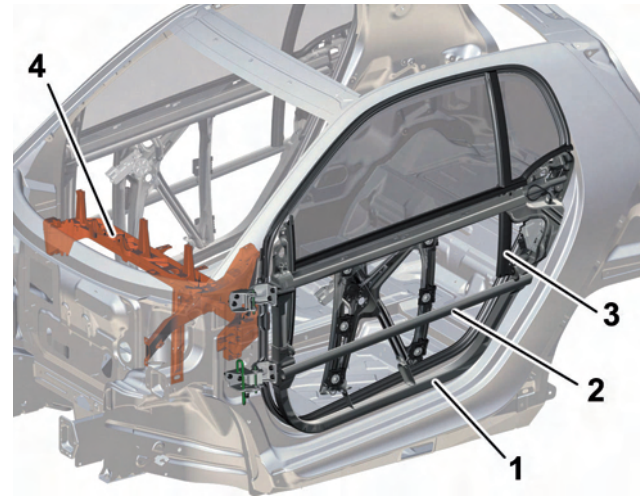

P72.00-2185-00

Door structure

- 1 Door carrier module
- 2 Diagonal strut
- 3 Side window slot frame
- 4 Cockpit crossmember

Emergency opening

Normally, the smart fortwo is opened from outside via the standard-equipment central locking system using the transmitter key.

If the battery in the transmitter key cannot supply enough power, a lock cylinder installed behind a small cover under the handle of the left door can be used to open the driver door manually in an emergency.



P80.20-3225-00

- 1 Lock cylinder for emergency opening

Doors/flaps

Body

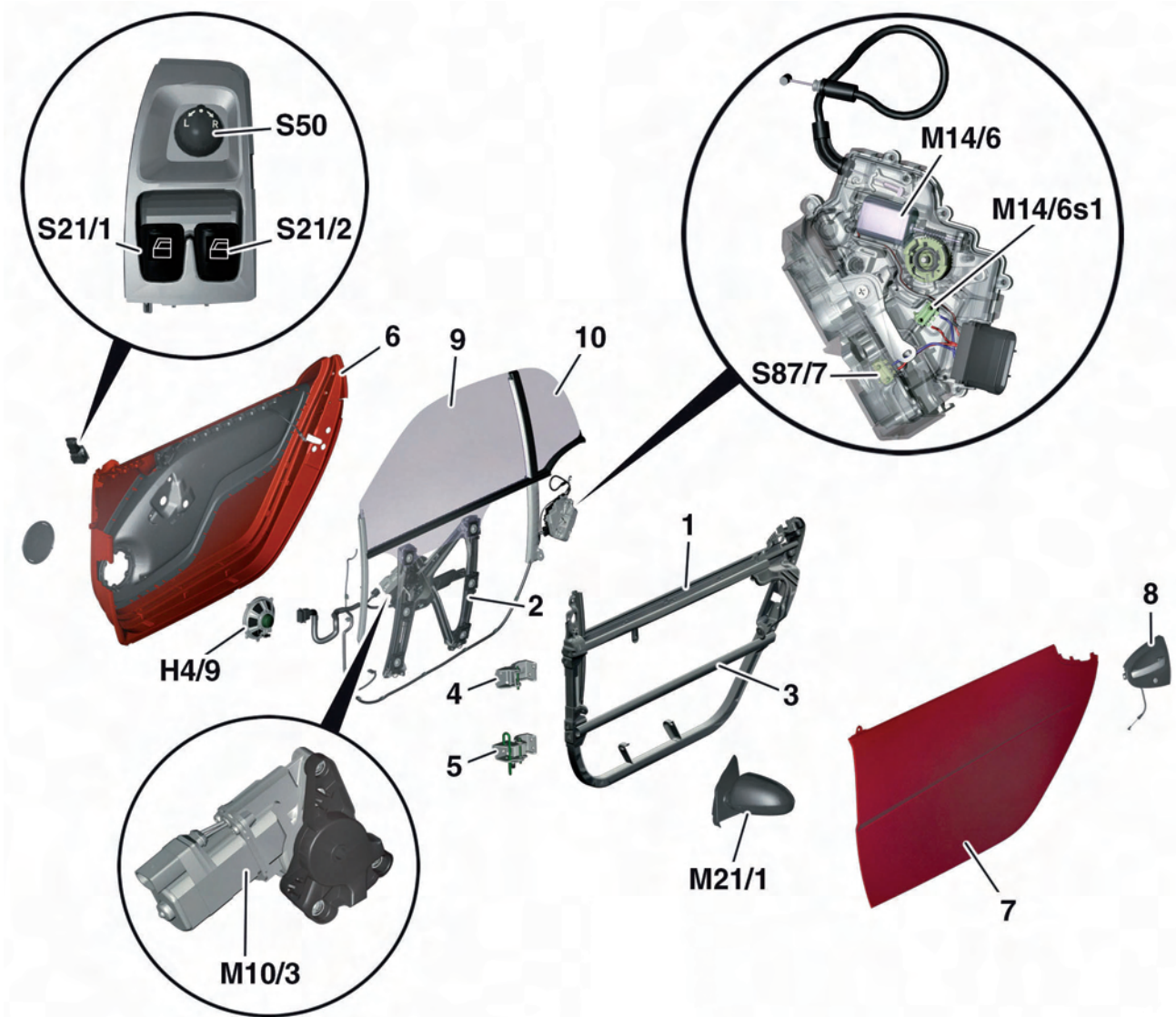

Design of driver door with power window and electric outside mirror

P72.10-3403-00

- | | | | |
|----|----------------------------|---------|--|
| 1 | Door carrier module | H4/9 | Left front speaker |
| 2 | Window lifter mechanism | M10/3 | Left power window motor |
| 3 | Diagonal strut | M14/6 | Left door CL [ZV] motor |
| 4 | Top door hinge assembly | M14/6s1 | Left door CL [ZV] microswitch |
| 5 | Bottom door hinge assembly | M21/1 | Left electrically adjustable and heated outside mirror |
| 6 | Inner door lining | S21/1 | Left power window switch |
| 7 | CBS door paneling | S21/2 | Right power window switch |
| 8 | Curved handle | S50 | Outside mirror adjustment switch |
| 9 | Side window | S87/7 | Left door rotary tumbler microswitch |
| 10 | Triangular window | | |

Doors/flaps

Rear-end door

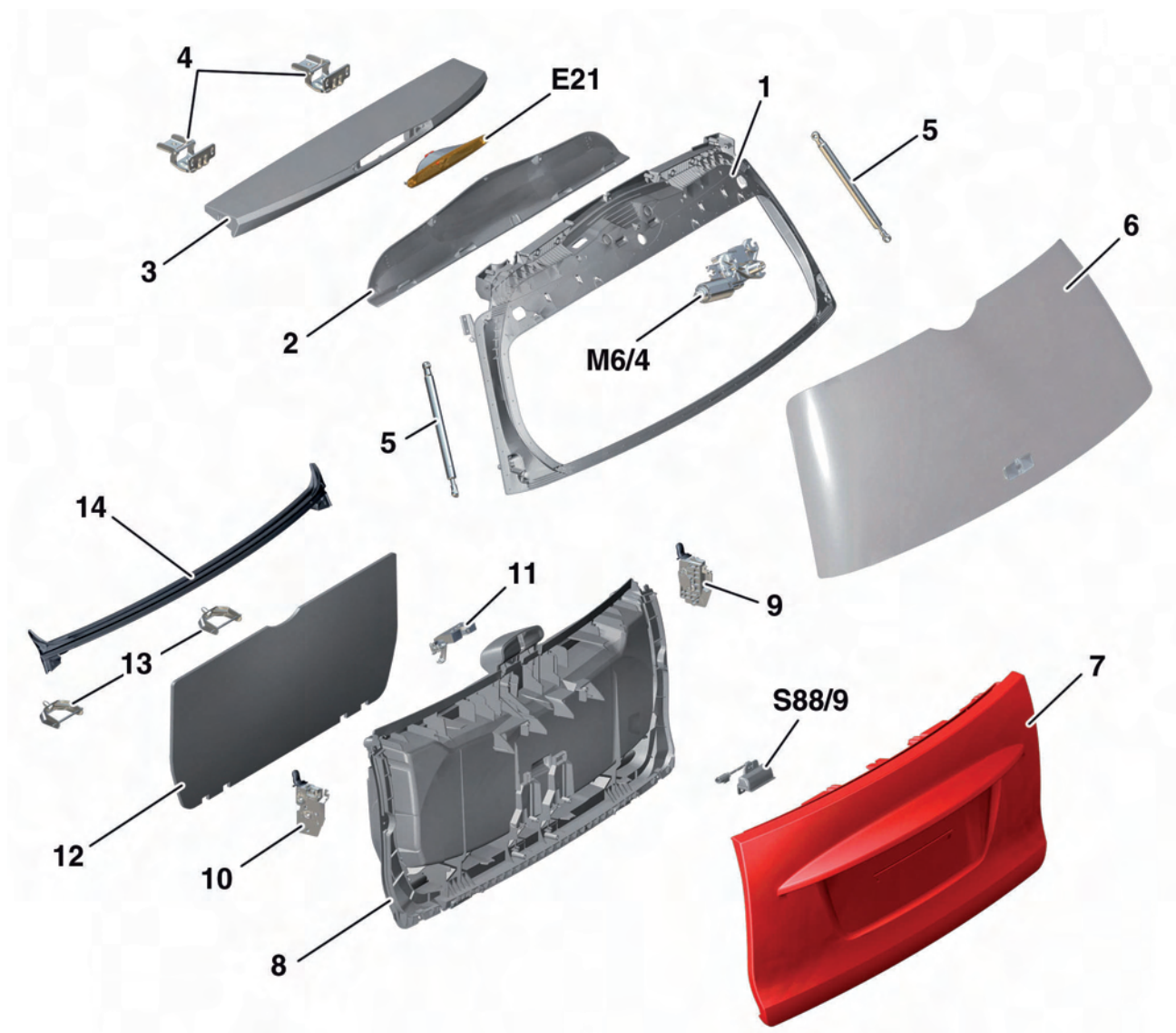

P72.20-2599-00

Design of rear-end door shown on the smart fortwo coupé

- | | | | |
|----|--|-------|----------------------------------|
| 1 | Upper rear-end door | 11 | Door lock of upper rear-end door |
| 2 | Upper rear-end door paneling | 12 | Door panel lining |
| 3 | Rear spoiler | 13 | Lower rear-end door hinges |
| 4 | Upper rear-end door hinges | 14 | Seal |
| 5 | Gas-operated strut | | |
| 6 | Rear window | E21 | Center high-mounted brake lamp |
| 7 | CBS rear-end door paneling | M6/4 | Rear-end door wiper motor |
| 8 | Lower rear-end door | S88/9 | Rear-end door handle switch |
| 9 | Right door lock of lower rear-end door | | |
| 10 | Left door lock of lower rear-end door | | |

Emergency unlocking of rear-end door

The rear-end door in the smart fortwo can be unlocked from the inside in an emergency, if the trunk lid central locking motor for operating the rotary tumbler is defective or de-energized.

Emergency unlocking in smart fortwo coupé

To do this, a small tab at the side of the trunk lid lock paneling must be carefully bent over or broken off to produce a small hole.

A shop-made wire must then be inserted through the small hole so that enough downward pressure is exerted on the relay lever in the door lock to unlock the rear-end door at the top.

A description of the procedure for manufacturing the emergency release wire in the workshop is given in the Workshop Information System (WIS).

Emergency unlocking in smart fortwo cabrio

In order to open the two door locks in the cabrio, a hole must be accurately marked on the inside of the rear-end door on each side. Then a hole of 0.2 in (5 mm) diameter is drilled through the paneling on each side of the rear-end door..

A suitable screwdriver is inserted into each hole and the rear-end door is unlocked by moving the screwdriver handles simultaneously in the directions of the arrows.

The exact dimensions for the holes and a detailed description of the procedure can be found in the Workshop Information System (WIS).

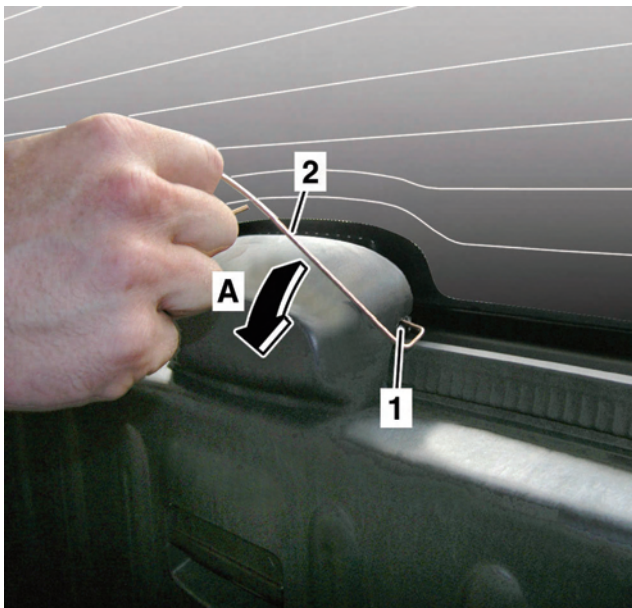

P72.20-2583-00

A Actuation direction

- 1 Tab/paneling hole on trunk lid lock
- 2 Emergency release wire

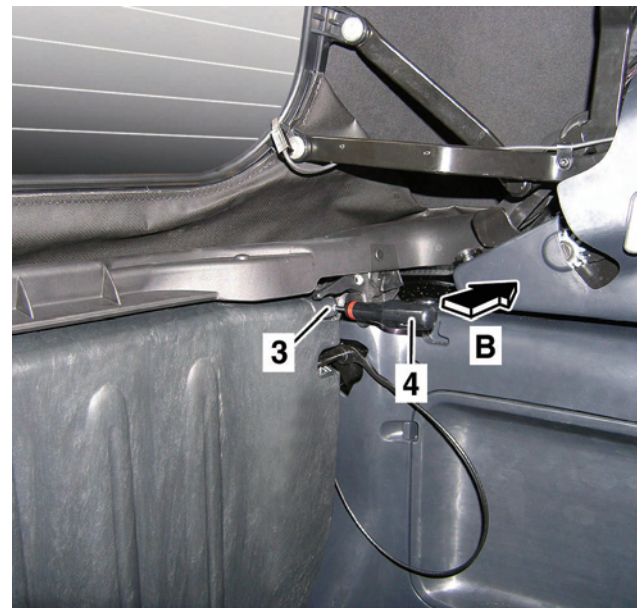

P72.20-2582-00

B Actuation direction

- 3 Hole (0.2 in (5 mm))
- 4 Screwdriver

Roof systems

Variants of roof system

Two roof variants are available for the model series 451 coupé. A fully electric Tritop fabric soft top is installed in the cabrio.

smart fortwo coupé

- Full roof made of glass fiber reinforced polyurethane (PU)
- Panoramic sunroof made of polycarbonate (PC)

smart fortwo cabrio

- Fully electric Tritop fabric soft top



Vehicle with PU roof

P65.00-2119-00



Vehicle with panoramic sunroof

P77.21-2226-00



Vehicle with fully electric Tritop fabric soft top

P77.00-2338-00

Hard roofs on smart fortwo coupé

Full roof

In the standard equipment pure version the smart fortwo coupé is supplied with the polyurethane (PU) full roof. The PU roof is only available in pitted matt black.

The PU full roof sits on the body and is bonded to the bodyshell structure.

Panoramic sunroof

A polycarbonate (PC) panoramic sunroof with steplessly variable roller sun blind is available for some equipment variants.

The roof module is bonded to the tridion safety cell. The latest in plastics technology makes it possible to use breakproof material extensively in the vehicle.

The material is covered with a scratch-resistant coating and the light transmission of the tint is approx. 13 %. The material also provides 100 % protection against UV light.

The steplessly adjustable inside roller blind can be used to block out the sun. The roller sun blind is made of a polyester fabric and covers the entire transparent area of the panoramic sunroof. The roof and roller blind can be replaced separately.

The panoramic sunroof is manufactured by a two-component injection molding process in which the second component material serves to blacken the edges.



P77.21-2225-00

Panoramic sunroof with roller sun blind

Roof systems

Tritop fabric soft top

The Tritop fabric soft top of the smart fortwo cabrio is the only one in the world that can be opened and closed while driving up to the maximum speed. The name TRITOP comes from the three main components of the soft top:

- Folding top open
- Rear soft top stowed
- Side supports removed

The soft top control system is fully electronic and features the following functions:

- Opening the folding top
- Closing the folding top
- Lowering the rear soft top
- Raising the rear soft top



Components of Tritop textile soft top

P77.30-2390-00

- 1 Folding top
2 Rear soft top

- 3 Left and right side supports

Soft top operation

The folding top and rear soft top are opened and closed using the power soft top switch on the electronic selector lever module control unit.

The folding top can also be opened remotely and automatically by means of a button on the transmitter key.

To operate the soft top via the power soft top switch the vehicle's ignition must be switched on.

A short press of the power soft top switch in the "Open" direction causes the folding top to open all the way to its end position.

The folding top must always be fully opened before the rear soft top can be opened. If the power soft top switch is then pressed again and held in the "Open" direction, the rear soft top is folded away for as long as the switch is actuated. As soon as the rear soft top has been stowed in its end position, its motors cut out and the switch can be released.

To close the soft top, the power soft top switch is pressed and held in the "Close" direction until the rear soft top has reached its upper end position and the motors of the rear soft top cut out; the switch can then be released.

If the power soft top switch is pressed and held again, the folding top closes until it reaches its own end position and the motor cuts out; then the switch can be released again.

The rear soft top and folding top lock automatically as soon as they reach their end positions.

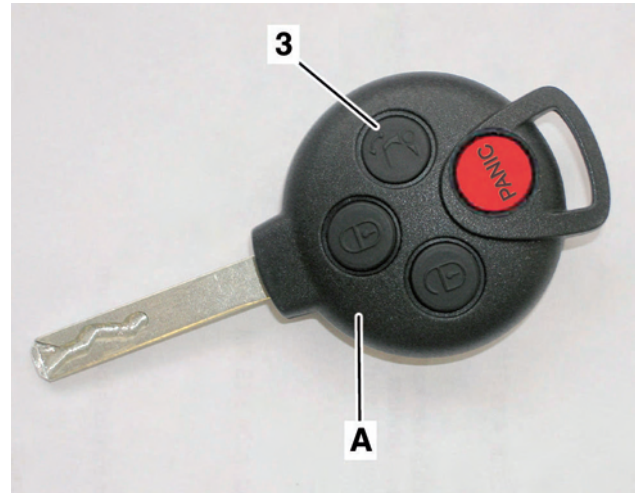

P80.35-2333-00

3 Folding top automatic open button

A Transmitter key



P77.00-2332-00

S84 Power soft top switch

i Note

For safety reasons, it is not possible to close the folding top automatically. There would be a risk of injury during the closing process because limbs of vehicle occupants could become trapped between the roof frame and folding top in the area of the windshield.

Roof systems

Targa roof position

In the targa roof position, the folding top is fully opened, the side supports are removed and the rear soft top is closed.

The targa roof position is important with regard to the operation of the folding top because the side supports must be inserted before the folding top can be closed. The side supports are detected by a mechanical catch in the roof cassette lock.

Soft top control

The central controller unit of the soft top is the SAM control unit.

The SAM control unit reads in the actuation request from the power soft top switch and actuates the appropriate motors depending on the position and status of the soft top.

The soft top is powered by a total of three motors. A central motor in the roof cassette is responsible for opening and closing the folding top. The folding and raising of the rear soft top is carried out by two motors in the left and right main bearings of the soft top.

The soft top also incorporates the center high-mounted brake lamp and a glass rear window with an integral rear window heater, which is also activated by the SAM control unit.

Function sequence of soft top actuation

Function requirements:

- Switch circuit 15 ON

Pressing the power soft top switch sends a direct signal to open or close to the SAM control unit. The SAM control unit reads in the signal, checks whether the function requirements are satisfied and determines the status of the soft top via the microswitches installed on the soft top. If all the preconditions are met, the SAM control unit actuates the appropriate motor(s) for the desired operation.



P77.00-2340-00

Targa roof position

Roof systems

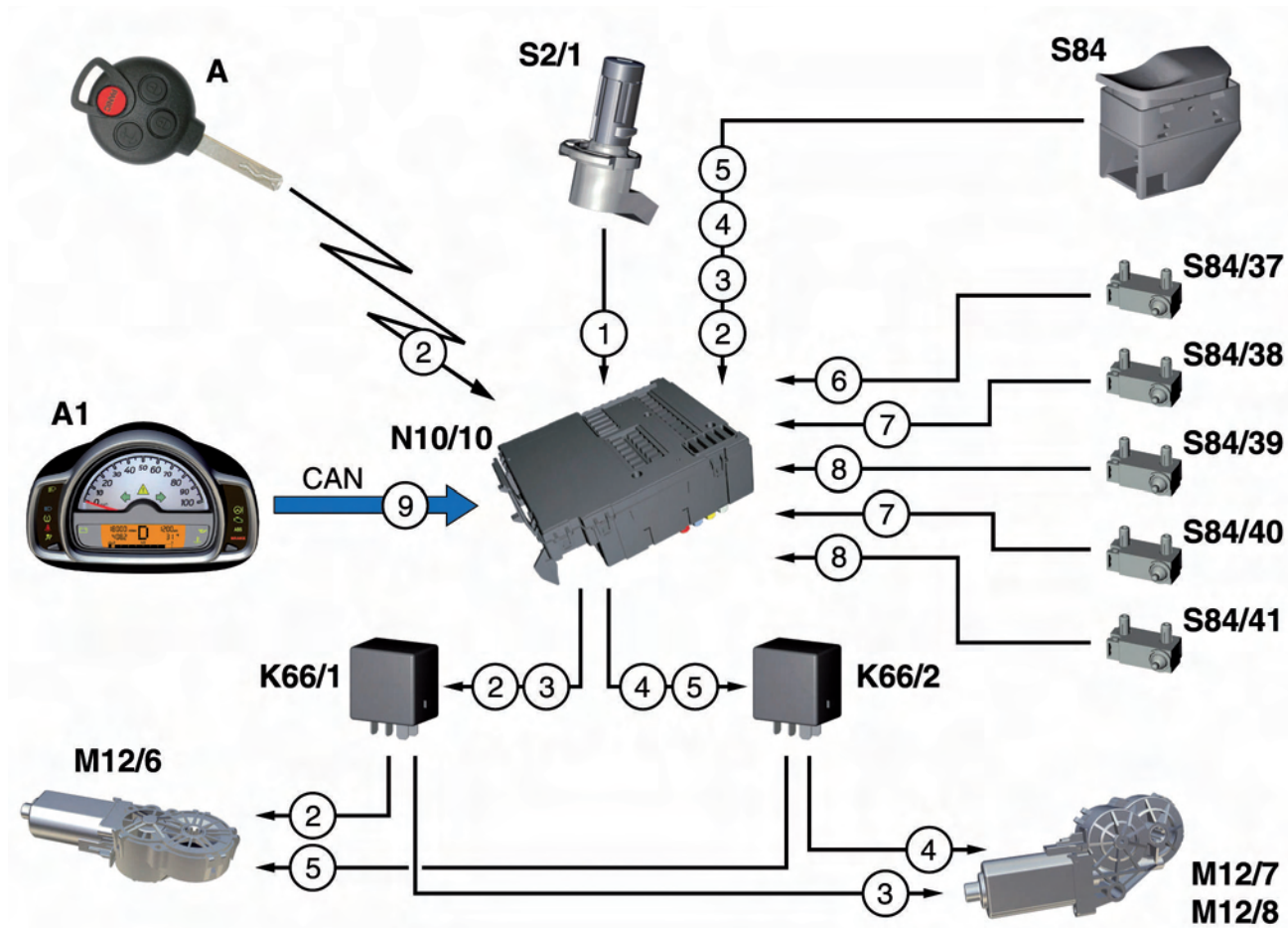

P77.39-2210-00

Data flow chart of soft top control

- 1 Circuit 15 ON
- 2 Request to open folding top
- 3 Request to open rear soft top
- 4 Request to close rear soft top
- 5 Request to close folding top
- 6 Status of soft top
- 7 Status of roof cassette latch
- 8 Status of rear soft top
- 9 Vehicle speed

- A1 Instrument cluster
- K66/1 Open soft top relay
- K66/2 Close soft top relay
- M12/6 Electric soft top motor
- M12/7 Left soft top drive
- M12/8 Right soft top drive
- N10/10 SAM control unit
- S2/1 Ignition/starter switch
- S84 Power soft top switch
- S84/37 Folding top microswitch
- S84/38 Left roof cassette microswitch
- S84/39 Right rear soft top microswitch
- S84/40 Right roof cassette microswitch
- S84/41 Left rear soft top microswitch

- A Transmitter key
- CAN Controller Area Network (data bus/CAN bus)

Central locking

Central locking (CL [ZV])

The central locking in the smart fortwo includes the locking and unlocking of both doors and the fuel filler flap, and the opening of the rear-end door in the smart coupé or the opening of the soft top on the smart cabrio. A distinction is drawn between manual and automatic functions.

Manual functions:

- Remote control with the transmitter key
- Door opening from the inside
- Operation via the interior CL [ZV] locking and unlocking switches in the cockpit switch group
- Manual unlocking with the transmitter key at the driver-side door lock

Automatic functions:

- Speed-dependent locking
- Emergency opening after crash detection
- Relocking

Unlocking or locking via the transmitter key

When the Unlock or Lock button on the transmitter key is pressed, it sends a radio signal to the SAM control unit. The SAM control unit checks the access authorization of the transmitter key. If the access authorization is valid, it actuates the following motors directly to unlock or lock the vehicle:

- Right door CL [ZV] motor
- Left door CL [ZV] motor
- Fuel filler flap CL [ZV] motor

When the vehicle is globally unlocked, the rear-end door handle switch is enabled; and when the vehicle is locked, it is disabled.

If the rear-end door handle switch is actuated when the central locking has been globally unlocked, the SAM control unit directly actuates the trunk lid CL [ZV] motor to unlock the rotary tumbler.

Selective unlocking

If the Unlock button on the transmitter key is pressed once, only the driver door and fuel filler flap are unlocked. The anti-theft alarm system is deactivated and all turn signal indicators flash once.

Global unlocking

If the Unlock button on the transmitter key is pressed again, the passenger door is unlocked and the rear-end door handle switch is enabled. The turn signal indicators flash again once.

Door opening from the inside

The vehicle doors can always be opened from the inside with the door handle regardless of the status of the central locking. In this case, only the respective vehicle door and the fuel filler flap are unlocked.

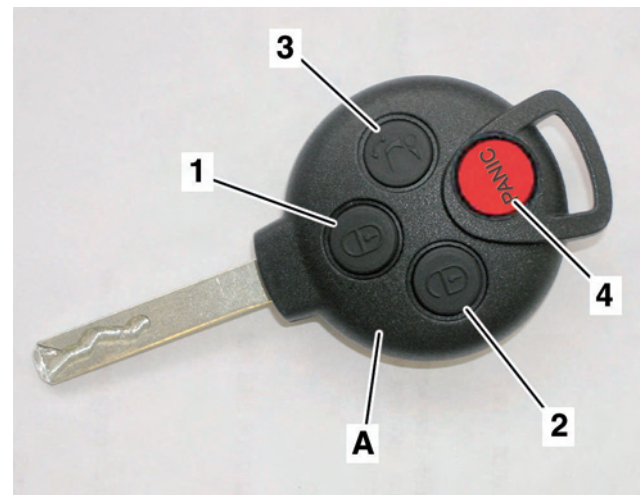

P80.35-2332-00

- A Transmitter key
- 1 Locking button
- 2 Unlocking button
- 3 Open folding top button (cabrio)
Open rear-end door button (coupé)
- 4 PANIC button



Central locking

PANIC alarm

Pressing the PANIC button for at least 1 s triggers an acoustic alarm. The turn signal indicators also flash. The alarm is deactivated when

- Circuit 15 is switched ON or
- The PANIC button is pressed

Unlocking and locking from the inside via the switches in the cockpit switch group

When the side doors and the rear-end door are closed, pressing the "Lock or unlock" switch in the cockpit switch group causes a signal to be sent straight to the SAM control unit. This actuates the central locking motors. The vehicle doors and the fuel filler flap are either locked or unlocked accordingly and the rear-end door handle switch is either enabled or disabled.

Special function:

If the vehicle cannot be locked using the transmitter key due to a flat battery in the key, proceed as follows:

- Open driver door
- Switch circuit 15 ON
- Actuate inside CL [ZV] switch
- Within 5 s, switch circuit 15 OFF and remove transmitter key
- Close driver door, vehicle is locked.

Manual unlocking of the driver door with the transmitter key at the door lock

When the door lock on the driver door is operated with the transmitter key, the driver door and (if the on-board power supply voltage is sufficient) the fuel filler flap are unlocked.

If the antitheft alarm system on the vehicle is armed, an alarm is triggered.

Speed-dependent locking

The vehicle is automatically locked if circuit 15 is ON and the vehicle speed exceeds 8 mph (14 km/h). Speed-dependent locking can be activated or deactivated as required.

Relocking

This function relocks the vehicle automatically if none of the doors is opened 60 s after unlocking.

Emergency opening after crash recognition

This functions unlocks the doors after an accident that triggers a crash signal.

Remote rear-end door opening (smart fortwo coupé only)

When the "Open rear-end door" button on the transmitter key is pressed, it sends a radio signal to the SAM control unit. This checks the access authorization of the transmitter key. If the access authorization is valid, the SAM control unit actuates the trunk lid CL [ZV] motor directly.

Remote folding top opening (smart fortwo cabrio only)

When the "Open folding top" button on the transmitter key is pressed, it sends a radio signal to the SAM control unit. This checks the access authorization of the transmitter key. If the access authorization is valid, the SAM control unit actuates the electric soft top motor directly.

i Note

The radio signal for unlocking the door is picked up by an antenna integrated in the SAM control unit. There is no external antenna for the central locking.

Central locking

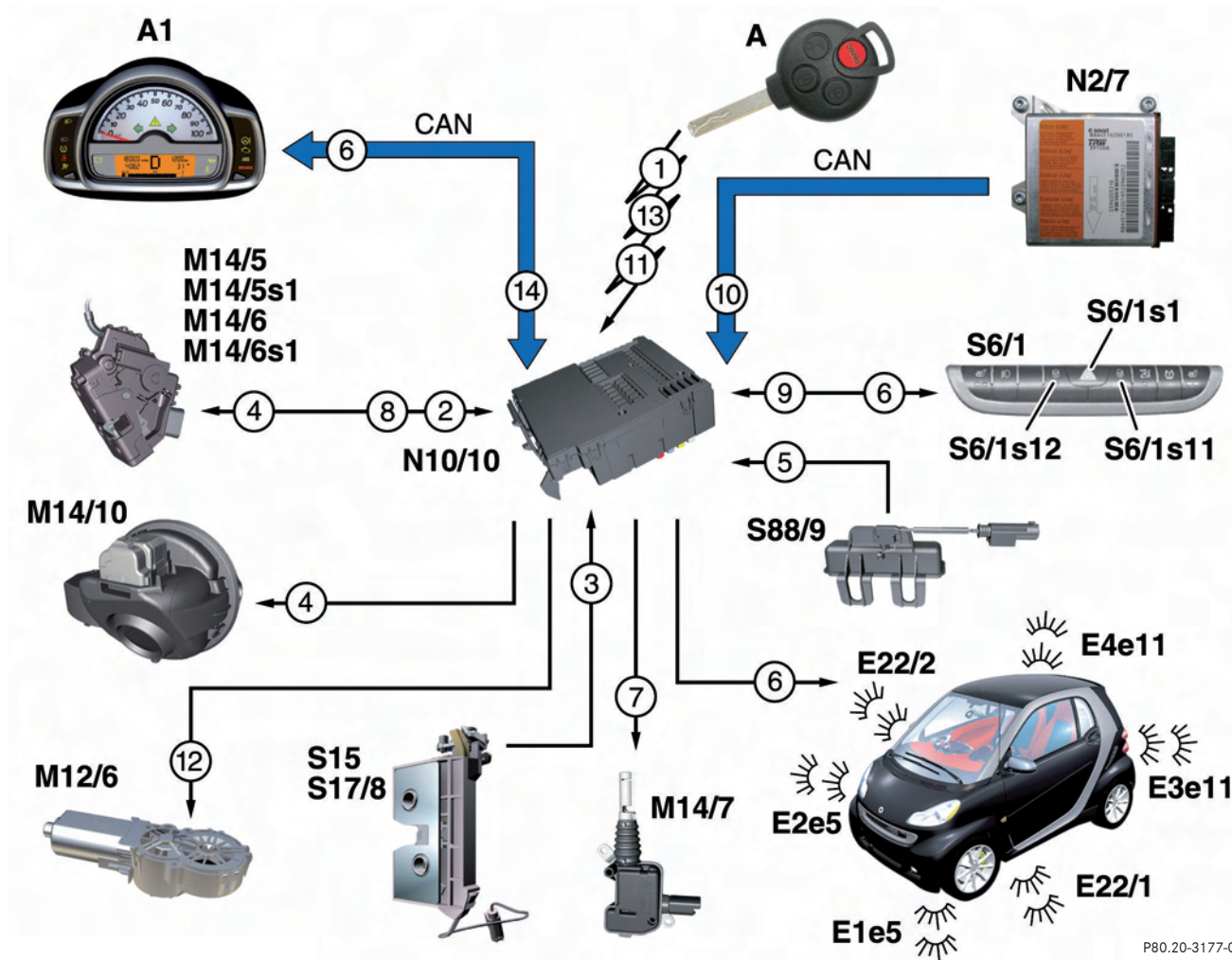

P80.20-3177-00

- | | | | |
|-------|--|---------|---|
| 1 | Unlocking/locking request | E22/1 | Left additional turn signal lamp |
| 2 | Doors status | E22/2 | Right additional turn signal lamp |
| 3 | Rear-end door status | M12/6 | Electric soft top motor (cabrio) |
| 4 | Unlocking/locking actuation | M14/5 | Right door CL [ZV] motor |
| 5 | Rear-end door unlocking request | M14/5s1 | Right door CL [ZV] microswitch |
| 6 | Visual feedback actuation | M14/6 | Left door CL [ZV] motor |
| 7 | Rear-end door unlocking actuation | M14/6s1 | Left door CL [ZV] microswitch |
| 8 | Unlocking via inside door opener request | M14/7 | Rear-end door CL [ZV] motor |
| 9 | Inside unlocking/locking request | M14/10 | Fuel filler flap CL [ZV] motor |
| 10 | Emergency opening request | N2/7 | Restraint systems control unit |
| 11 | Rear-end door opening request (coupé) | N10/10 | SAM control unit |
| 12 | Open soft top actuation (cabrio) | S6/1 | Cockpit switch group |
| 13 | Open soft top request (cabrio) | S6/1s1 | Hazard warning flasher switch |
| 14 | Vehicle speed | S6/1s11 | Inside unlock CL [ZV] switch |
| A1 | Instrument cluster | S6/1s12 | Inside lock CL [ZV] switch |
| E1e5 | Left turn signal light | S15 | Remote trunk opening switch (coupé) |
| E2e5 | Right turn signal light | S17/8 | Trunk lid rotary tumbler microswitch (cabrio) |
| E3e11 | Left brake/turn signal light | S88/9 | Rear-end door handle switch |
| E4e11 | Right brake/turn signal light | A | Transmitter key |
| | | CAN | Controller Area Network (data bus/CAN bus) |

Anti-theft alarm system (ATA [EDW])

ATA [EDW] system

The anti-theft alarm system (ATA [EDW]) monitors all relevant inputs for their non-actuated state. If a change of status is detected at one of the monitored inputs, an acoustic and visual alarm is issued.

The acoustic signals are output by the alarm signal siren with inclination sensor. The visual signals are output via the turn signal indicators. The SAM control unit is the master control unit for the anti-theft alarm system (ATA [EDW]).

When armed, the anti-theft alarm system (ATA [EDW]) monitors:

- The doors
- The rear-end door
- The alarm siren with inclination sensor
- The position change of the vehicle
- Movements in the interior compartment

Activation and deactivation

The anti-theft alarm system (ATA [EDW]) is activated when the vehicle is locked with the transmitter key. The anti-theft alarm system (ATA [EDW]) is deactivated by unlocking the vehicle with the transmitter key or by inserting an authorized transmitter key in the ignition lock and turning circuit 15 ON.

Alarm triggering

An alarm is triggered when the SAM control unit receives a status change from the following components:

- ATA [EDW] microwave sensor
- Inclination sensor in alarm siren
- Trunk lid rotary tumbler microswitch
- Right door rotary tumbler microswitch
- Left door rotary tumbler microswitch

Alarm output

The alarm is output via the turn signal indicators and the alarm siren with inclination sensor.

Interior protection/tow-away protection

The ATA [EDW] microwave sensor is activated approx. 30 s after the vehicle is locked. Interior protection can be deactivated using the tow-away protection/interior protection switch.

The inclination sensor in the alarm siren with inclination sensor registers a positional change of the vehicle. The inclination sensor, and thus the tow-away protection, can be deactivated using the tow-away protection/interior protection switch.

The interior protection or tow-away protection is reactivated automatically the next time the vehicle is locked.

Anti-theft alarm system (ATA [EDW])

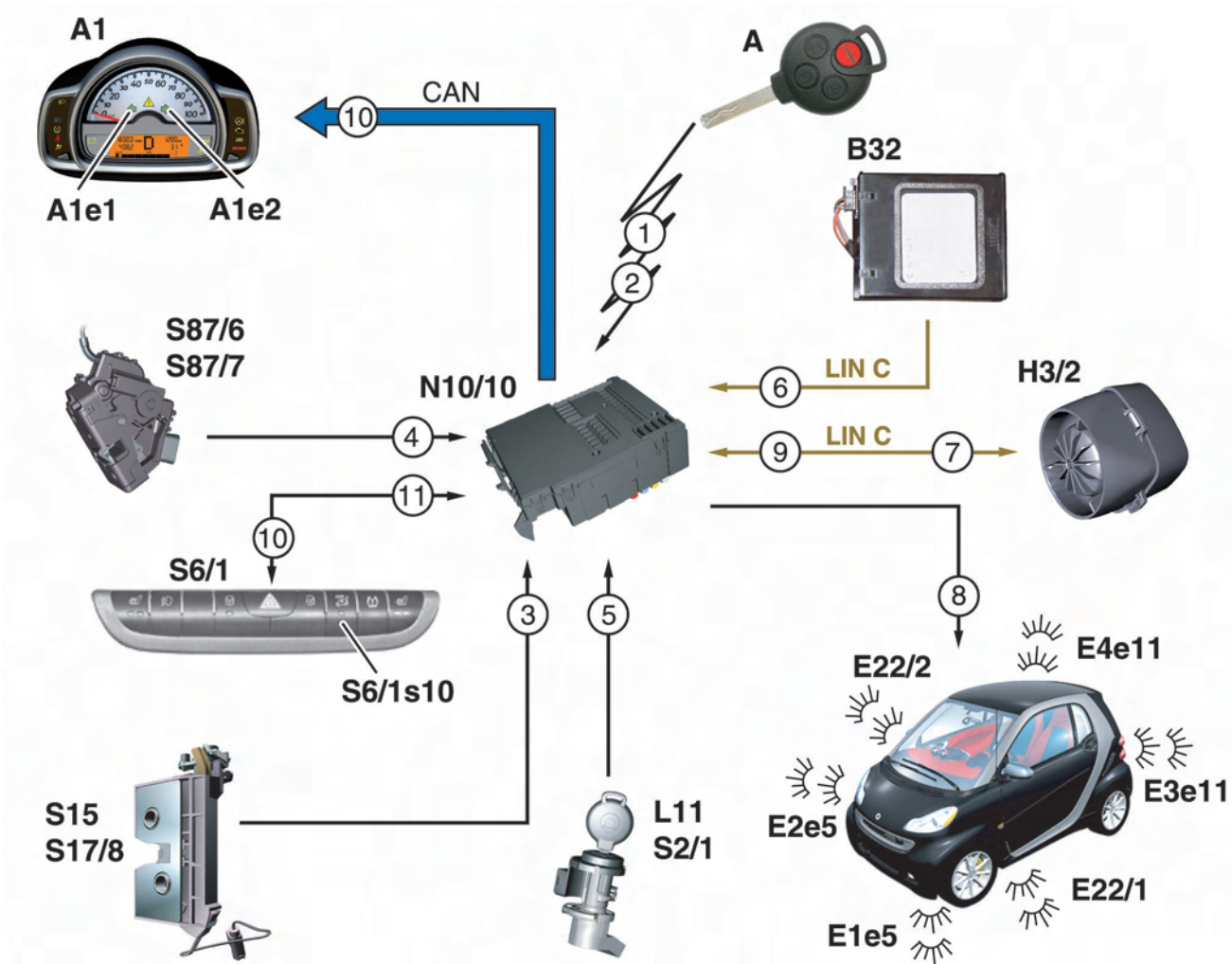

P80.50-2648-00

Data flow chart of anti-theft alarm system (ATA [EDW])

1	Activate ATA [EDW] with transmitter key	E4e11	Right brake/turn signal light
2	Deactivate ATA [EDW] with transmitter key	E22/1	Left additional turn signal lamp
3	Rear-end door status	E22/2	Right additional turn signal lamp
4	Doors status	H3/2	Alarm siren with inclination sensor
5	Deactivate ATA [EDW] via ignition/starter switch	L11	Transponder coil
6	Movement in interior signal	N10/10	SAM control unit
7	Alarm siren actuation	S2/1	Ignition/starter switch
8	Turn signal lights actuation	S6/1	Cockpit switch group
9	Inclination sensor status change	S6/1s10	Tow-away protection/interior protection switch
10	Turn signal indicator actuation	S15	Remote trunk opening switch (coupé)
11	Tow-away protection/interior protection shutoff	S17/8	Trunk lid rotary tumbler microswitch (cabrio)
A1	Instrument cluster	S87/6	Right door rotary tumbler microswitch
A1e1	Left turn signal indicator lamp	S87/7	Left door rotary tumbler microswitch
A1e2	Right turn signal indicator lamp	A	Transmitter key
B32	ATA [EDW] microwave sensor	CAN	Controller Area Network (data bus/CAN bus)
E1e5	Left turn signal light	LIN C	Interior Local Interconnect Network 2
E2e5	Right turn signal light		
E3e11	Left brake/turn signal light		

Auto on/off headlamps (Autolight function)

The basic equipment can be expanded with the convenient Autolight function as special equipment.

A rain sensor/light sensor is additionally installed for the Autolight function. The rain sensor/light sensor is located on the inside of the windshield near the inside rearview mirror. The rain/light sensor distinguishes between light and dark by measuring the intensity of the light and thereby enables the exterior lights to be switched on and off automatically according to the ambient light conditions. The activated light corresponds to the "usual" driving lights with low beam.

Special feature

The Autolight function is activated by moving the combination switch to the AUTO position. The AUTO position of the combination switch is only available in vehicles with Autolight function installed as special equipment.

Signal flow

When the Autolight function is activated and darkness is detected, the rain sensor/light sensor sends a corresponding signal via the LIN B to the SAM control unit. This evaluates the signal and actuates the appropriate lamps over direct lines.



B38 Rain sensor/light sensor

P54.21-2893-00

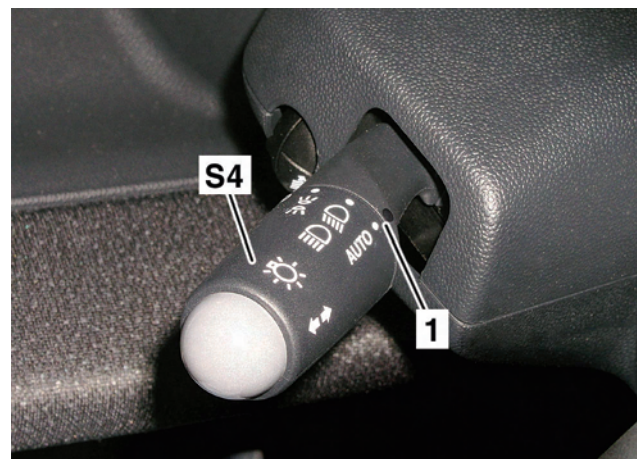

1 AUTO position

P54.25-5577-00

S4 Combination switch

Coming-Home function

The function is a component of the Autolight function. When the vehicle is locked or unlocked, the driving lights are switched on for 12 s. The function is also activated by the rain sensor/light sensor; the position of the combination switch is immaterial. The Coming-Home function can only be deactivated by coding in the workshop.

Audio system

Radio and sound systems

Two radio variants are available as special equipment and accessories for model series 451.

Variant 1:

smart radio 9 with radio and CD player



smart radio 9

P82.60-5801-00

Variant 2:

smart radio 10 with radio, integral 6-disk CD changer, MP3-compatible



smart radio 10

P82.60-5802-00

Audio system

Speaker sound variants

Basic package

A basic package with one broadband speaker in each door is available as special equipment.

Sound system

The sound system (special equipment) includes two tweeters/midrange speakers and a subwoofer. Due to the modular design, these components can also be retrofitted individually as accessories. The smart MP3 interface (AUX jack) is installed as standard.

smart accessory sound system (two tweeters, two midrange speakers): The tweeters are simply clipped in place under the instrument panel; the wiring harness is already installed. The door panels must be removed in order to install the midrange speakers.

Subwoofer: The driver seat is removed and the subwoofer is bolted on together with the driver seat; the wiring harness is already there under the floor carpeting.

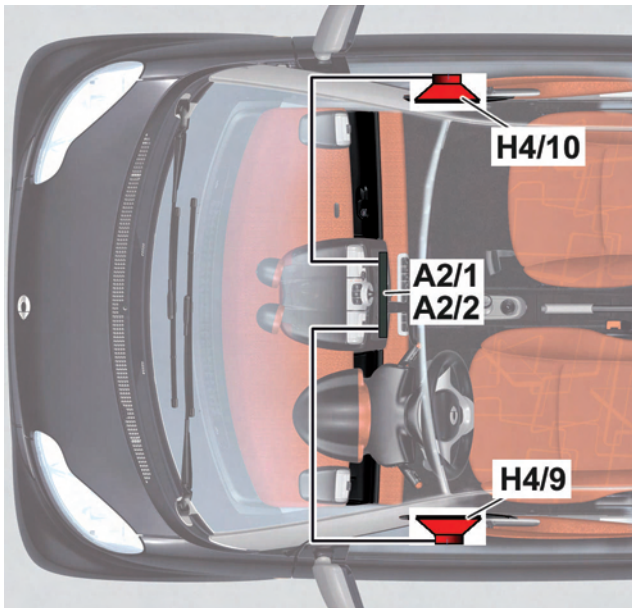

P82.62-3243-00

Speaker diagram - basic package

- A2/1 smart radio 9
- A2/2 smart radio 10
- H4/9 Left front speaker
- H4/10 Right front speaker

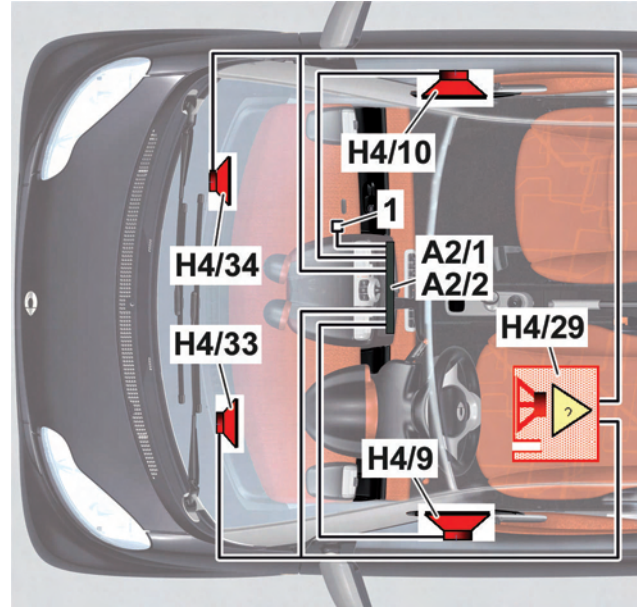

P82.62-3242-00

Speaker diagram - sound systems

- 1 smart MP3 interface (AUX jack)
- A2/1 smart radio 9
- A2/2 smart radio 10
- H4/9 Left front speaker
- H4/10 Right front speaker
- H4/29 Subwoofer
- H4/33 Left tweeter
- H4/34 Right tweeter

Climate control

Heating

Model series 451 is equipped with a heating system as standard. The temperature and blower speed are each set by means of a slide control. The temperature blend flap in the air distribution box is operated mechanically via a Bowden cable. The air distribution is adjusted with a 360° rotating button switch. The air distribution flap is actuated mechanically via a cable shaft.

The blower can be adjusted in four power stages. The rpm is regulated by means of an external series resistor:

- Stage 0: Blower off
- Stage 1: Blower on
Weak, low speed
- Stage 2: Blower on
Strong, higher speed
- Stage 3: Blower on
Stronger, higher speed
- Stage 4: Blower on
Maximum strength

The rear window heater button in the heater/AC operating unit switches on the heated rear window and the function LED in the button lights up.

The heated rear window is switched off either automatically via a timer control or by pressing the rear window heater button again. The function LED goes out. If the on-board power supply voltage is too low, the rear window heater is switched off automatically.

Temperature-regulated air conditioning

The control functions of air distribution, blower output, temperature setting and heated rear window are as described for the heater.

Activation of the air conditioning:

- Press A/C button. The function LED lights up.

Deactivation of the air conditioning:

- Press A/C button. The function LED goes out.

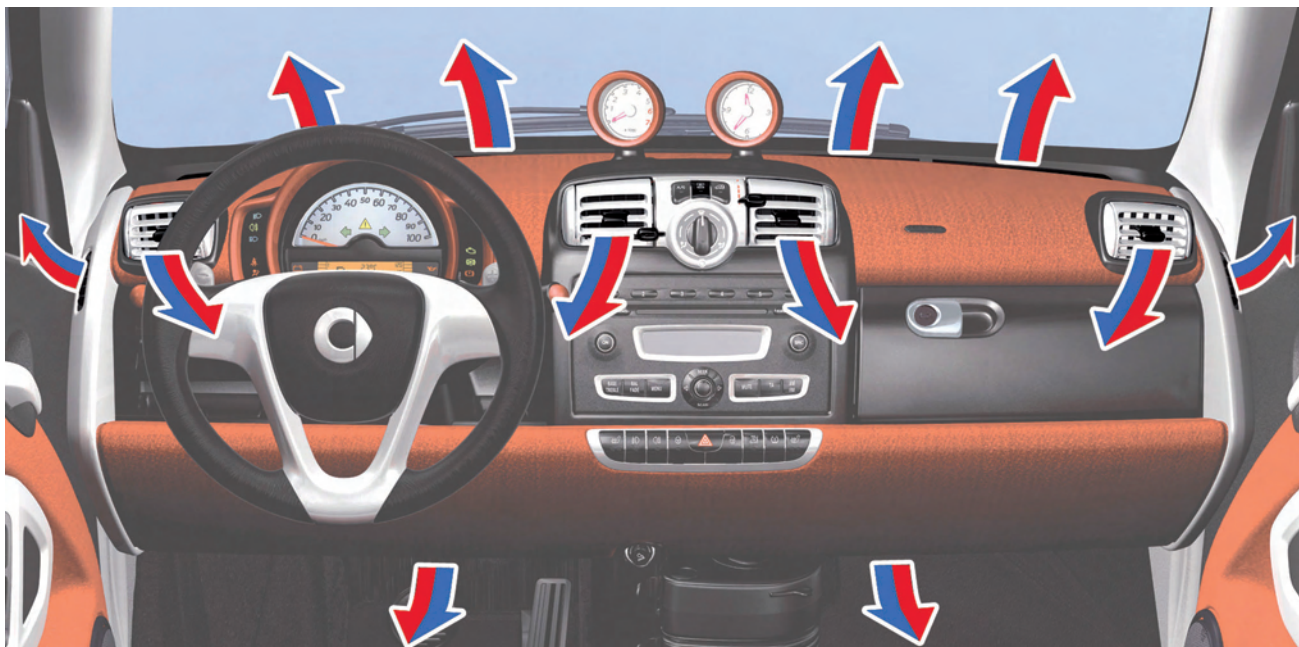

Air outlets for heater and temperature-regulated air conditioning

P83.10-2640-00

Climate control

For safety reasons, if the air distribution lever is moved precisely to "Windshield Defrost", the air conditioning switches itself on automatically with no action by the occupants in order to ensure that the windshield is defrosted and dried as quickly as possible.

In this case the function LED does not light up to indicate that the air conditioning has been activated automatically.

When the air distribution lever is moved away from the Defrost position, this function is canceled. This happens regardless of the programmed temperature or blower stage. In addition, air recirculation mode is deactivated if it is on.

The air recirculation flap and the temperature blend flap are actuated via electric actuator motors.

The cooling output of the refrigerant compressor is controlled by means of an appropriate CAN signal from the SAM control unit.

The interior temperature is measured by an integral interior temperature sensor located on the bottom of the heater/air conditioning operating unit.

Air recirculation mode

When the air recirculation mode button is pressed, the fresh air flap is closed. This causes the air to circulate in the interior compartment only. The function LED in the button lights up during air recirculation mode.

i Note

The air conditioning cannot be operated in temperatures below 37 °F (3 °C).

i Note

The temperature-regulated air conditioning switches off temporarily:

- If the engine speed is too low
- When starting up
- At a coolant temperature greater than 239 °F (115 °C),
- At outside temperatures below 37 °F (3 °C).



P83.40-3926-00

Heater/AC operating unit

Customized Bodypanel System (CBS)

CBS concept

The CBS concept is composed of "bodypanels" that are installed as detachable parts around the vehicle and form a large proportion of the vehicle's external skin.

Front end module

The statics of the CBS in the area of the front end are based on a one-piece, bolt-on front end module with integral pedestrian protection.

The front end module is injection molded polypropylene plastic stiffened with partial reinforcement panels on the longitudinal frame member.

The front end module also holds the engine radiator module, including the AC condenser, the headlamps, the front fog lamp and the CBS bodypanels.

Bodypanels

Depending on the color variant, the bodypanels are supplied either as colored plastic or with 2-coat metallic paintwork. The bodypanels are overcoated with a clearcoat to protect against UV radiation.

The bodypanel concept has proven to be robust and easy to repair in practice. If damaged, they can be replaced with little effort and at low cost.

Rear-end door

The inside of the rear-end door in the new smart fortwo coupé contains an integral compartment for accommodating the hazard warning triangle, the first aid kit or similar.

In the smart fortwo cabrio the stowage space is intended for crash-proof storage of the roof side supports.

Surfaces and paintwork

General features

- Galvanized body
- Cathodic immersion painting
- Seam sealing
- Powder paint
- tridion safety cell in two colors:
 - Black as standard equipment or silver as special equipment
- Painted CBS (Customized Bodypanel System) components

Paint of the Customized Bodypanel System

The plastic parts of the Customized Bodypanel System (CBS) are dyed through and/or painted. A two-coat system of base coat and clearcoat is applied.

Paintwork repairs are possible only if the paint coat has not been worn down to the polypropylene (PP) base material. A new paintwork structure can then be built up. Otherwise proper adhesion of the paint on the component cannot be guaranteed.



Customized Bodypanel System (CBS)

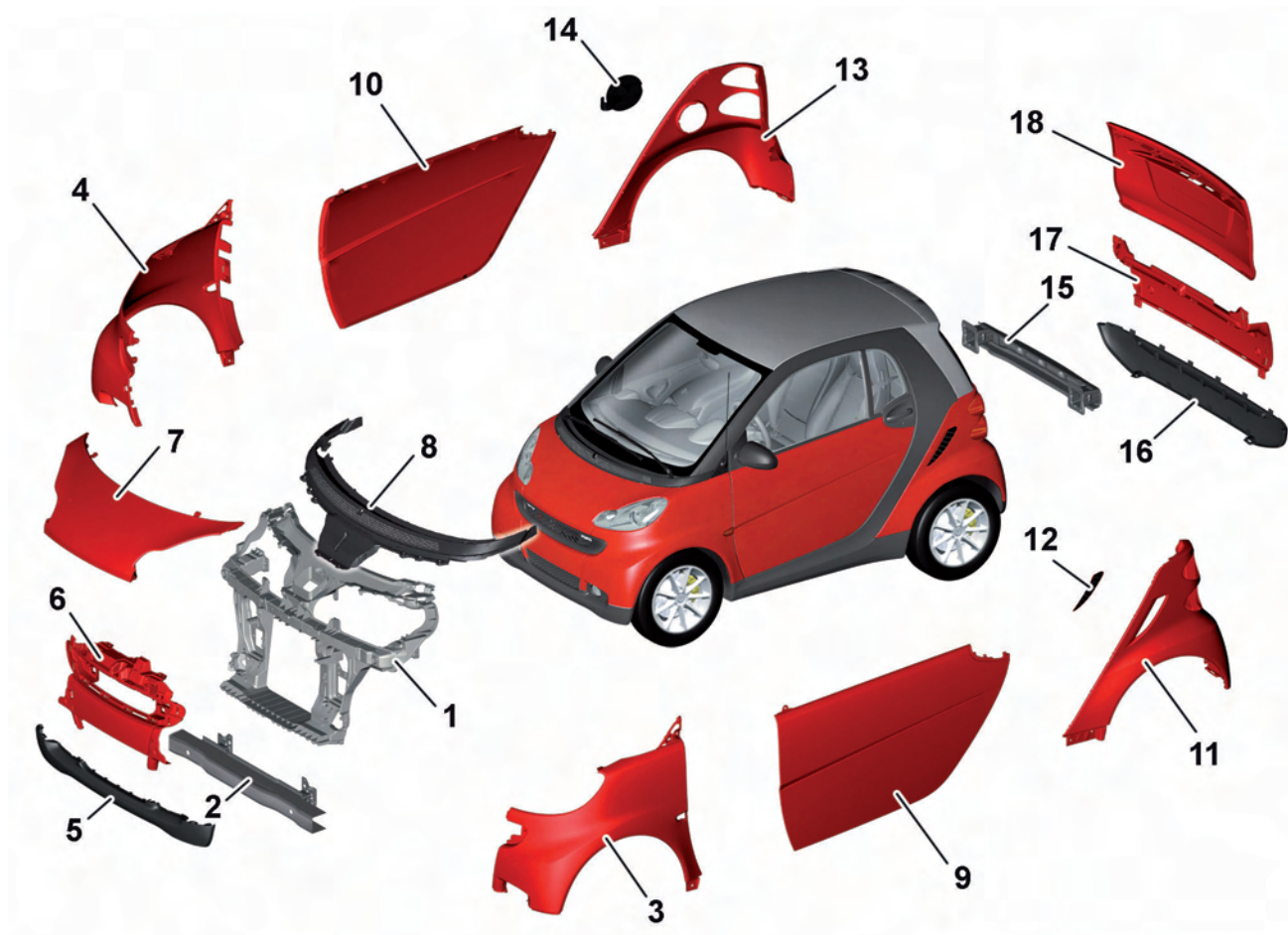

CBS components with front end module and crash management system (CMS)

P88.00-2375-00

- | | |
|--------------------------|----------------------------|
| 1 Front end module | 10 Right door paneling |
| 2 Front CMS | 11 Left side part |
| 3 Left fender | 12 Fresh-air intake |
| 4 Right fender | 13 Right side part |
| 5 Front spoiler | 14 Fuel filler flap |
| 6 Front center part | 15 Rear CMS |
| 7 Maintenance flap | 16 Exhaust system covering |
| 8 Fresh-air intake cover | 17 Rear center part |
| 9 Left door paneling | 18 Rear-end door paneling |

Seats

Seats, general

The safety integral seats on both sides of model series 451 can be adjusted in terms of seat length and backrest angle.

The backrest of the passenger seat can be folded forwards to allow through-loading of long loads. A TopTether anchor is bolted to the load compartment floor behind the passenger seat as standard. The guide for the TopTether belt is located on the backrest cover of the passenger seat level with the head restraint.

Seat heaters in the seat bolster and backrest cushion are available as special equipment.

Seat heaters

The seat heater special equipment in model 451 consists of two heating elements which are installed in the seat bolster and backrest cushion of each seat.

The seat heaters are activated separately for each side via the switch panel in the center console. Pressing the seat heater switch for the driver or passenger side switches on the seat heater at stage 2. Another press of the switch switches the seat heater to stage 1. If the switch is pressed a third time, the seat heater is switched off. The different stages are indicated in the relevant switch by the lighting of one LED for stage 1 and two LEDs for stage 2.

The heated seats control unit incorporates a temperature sensor that measures the ambient temperature. The heating elements in the driver and passenger seats follow a temperature profile based on this temperature. The heater output is constantly monitored to check the seat temperature.

Function

Function requirements:

- Switch circuit 15 ON

When the seat heater switch for the driver or passenger seat is pressed, a request signal is sent directly to the heated seats control unit. In the heated seats control unit the request for activation of the seat heater is processed with the function requirement.

The function requirement is transmitted by the ignition/starter switch straight to the SAM control unit, from where it is forwarded to the heated seats control unit.

If all the criteria for activation are satisfied, the appropriate seat heater is switched on by the heated seats control unit over a direct line.



P91.10-3254-00-

Integral seats



Supplemental restraint system

Restraint system

The restraint system consists of the following components:

- 2-stage full size airbag for driver and passenger
- Head/thoraxbag for driver and passenger in outsides of backrests
- Seat belt emergency tensioning retractors and belt force limiters for driver and passenger
- Passenger seat with Weight Sensing System (WSS) and belt tension sensor

In the event of a frontal impact and depending on the deceleration values, the driver airbag, the energy-absorbing steering column and the passenger airbag improve occupant protection by absorbing energy in a targeted manner and thus minimizing the risk of injury.

The pyrotechnical emergency tensioning retractors ensure that the occupants are properly restrained in their seats in a frontal impact and that they follow a defined forward displacement with the energy being absorbed by the belt force limiter.

The passenger airbag, emergency tensioning retractor and head/thoraxbag are switched off in accordance with the predefined weight class that the seat is assigned to. The airbag OFF indicator lamp is located in at the front above the interior lamp and lights up as soon as the shutoff function is activated.

In order to activate the systems in good time in the event of a crash and thus keep the physical consequences for the occupants low, sensors are installed to detect the occurrence of a collision at an early stage.

The following sensors are installed:

- Side trigger sensors in the left and right inner sills near the B-pillars for detecting a side impact
- Two frontal acceleration sensor on left and right of front crossmember
- Trigger sensor in the restraint systems control unit for detecting a frontal crash, a rear-end impact or a side-on collision

The central controller unit of the supplemental restraint system is the restraint systems control unit, which is located in the center of the vehicle on the crossmember under the instrument panel.

If the restraint systems control unit detects a fault in the system, this is indicated by the lighting of a warning lamp in the instrument cluster.

As well as triggering the restraint equipment, the following interventions are initiated by the restraint systems control unit in the event of a crash:

- Shutoff of engine and fuel pump
- Unlocking of door locks
- Activation of hazard warning lamp function

Supplemental restraint system

Weight sensing system (WSS)

To determine the situation in the interior compartment, the system detects whether the passenger seat is occupied. The seat occupied recognition pressure sensor determines the weight on the passenger seat by means of a pressure measurement from a seat mat filled with silicone oil. The force applied to the seat belt is measured via the belt tension sensor.

These two measured values are used by the Weight Sensing System (WSS) control unit to classify the weight on the seat. The values are transferred to the instrument cluster via CAN-B, which acts as a gateway to transfer the data to the restraint systems control unit via CAN.

The following conditions are defined depending on the occupant classification:

- Passenger seat not occupied:
Passenger airbag unit, passenger head/thoraxbag and passenger emergency tensioning retractor unit are disabled; the airbag OFF indicator lamp is switched ON.
- Passenger seat occupied - light weight (e.g. hand luggage):
Passenger airbag unit, passenger head/thoraxbag and passenger emergency tensioning retractor unit are disabled; the airbag OFF indicator lamp is switched ON.
- Passenger seat occupied - person detected:
The required restraint equipment is enabled; the airbag OFF indicator lamp is switched OFF.

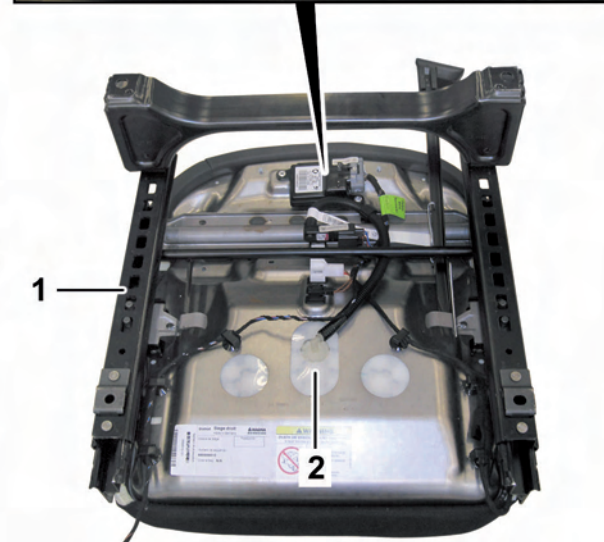
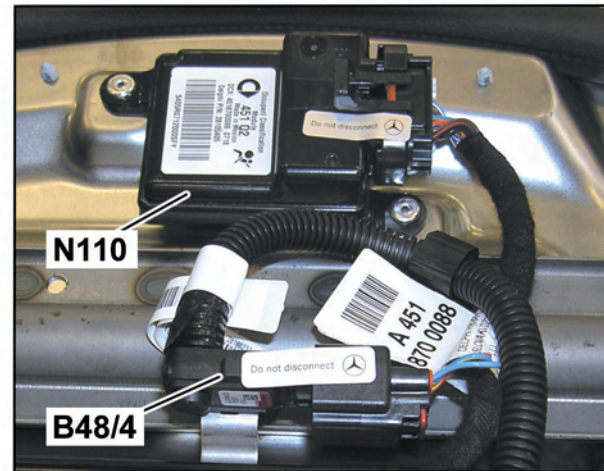

P91.60-3635-00

- | | |
|-------|---|
| 1 | Seat cushion frame |
| 2 | Seat mat filled with silicone oil |
| B48/4 | Seat occupied recognition pressure sensor |
| N110 | Weight Sensing System (WSS) control unit |

Supplemental restraint system

Body

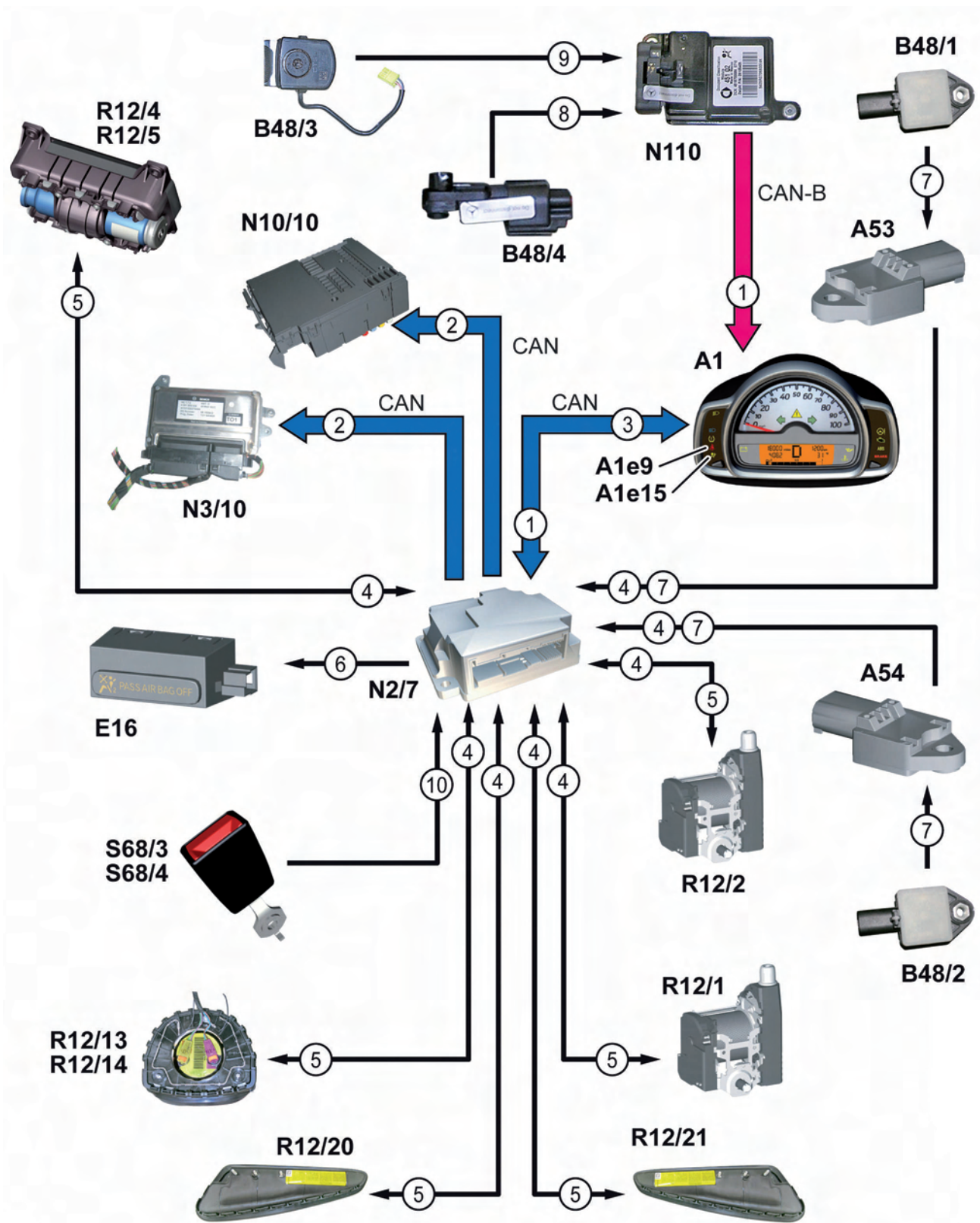

Data flow chart of supplemental restraint system

P91.60.3634-00

See next page for legend

Supplemental restraint system

1	Occupant classification		
2	Crash signal	N2/7	Restraint systems control unit
3	Warning and fault message output	N3/10	ME-SFI [ME] control unit
4	Squib and sensor monitoring	N10/10	SAM control unit
5	Trigger restraint equipment	N110	Weight Sensing System (WSS) control unit
6	Passenger airbag cutout display	R12/1	Left emergency tensioning retractor squib
7	Impact detection	R12/2	Right emergency tensioning retractor squib
8	Seat occupied status	R12/4	Passenger airbag ignition squib 1
9	'Belt tension sensor status	R12/5	Passenger airbag ignition squib 2
10	Seat belt buckle status	R12/13	Driver airbag ignition squib 1
		R13/14	Driver airbag ignition squib 2
A1	Instrument cluster	R12/20	Driver head/thoraxbag squib
A1e9	Seat belt warning lamp	R12/21	Passenger head/thoraxbag squib
A1e15	Airbag indicator and warning lamp	S68/3	Driver seat belt buckle restraint systems switch
A53	Driver head/thoraxbag sensor		
A54	Passenger head/thoraxbag sensor	S68/4	Passenger seat belt buckle restraint systems switch
E16	Automatic child seat recognition airbag OFF indicator lamp		
B48/1	Driver-side frontal acceleration sensor	CAN	Controller Area Network (data bus/CAN bus)
B48/2	Passenger-side frontal acceleration sensor	CAN-B	Controller Area Network bus class B (interior compartment)
B48/3	Belt tension sensor		
B48/4	Seat occupied recognition pressure sensor		



Bodyshell structure

The bodyshell structure of model series 451 exhibits the following features:

- tridion safety cell with high-strength steels and low weight:
 - smart fortwo coupé: 352 lb (160 kg)
 - smart fortwo cabrio: 379 lb (172 kg)
- Light alloy detachable parts
- Front CMS
- Rear CMS

tridion safety cell

The tridion safety cell which forms the bodyshell ensures that the vehicle is robust, absorbs energy by deformation in the event of a crash and provides optimum protection of the survival space to keep the occupants safe.

Design-based benefits of tridion safety cell:

- Its longitudinal members and crossmembers absorb impact energy at front and rear
- The most important major assemblies are safely accommodated in its underfloor area.
- Crash boxes attached at the front and rear absorb the impact energy at speeds of up to approx. 10 mph (16 km/h).
- It supports the extendable steering column via the cockpit crossmember.

The tridion safety cell consists of more than 50 percent high-strength steel sheet. These steels are alloyed to be more rigid and stronger than standard steel sheet.

The high-strength sheet metal parts can be worked in the same way as standard sheet metal and provide the following benefits:

- Improved torsional stiffness
- Optimized crash behavior
- Reduced metal sheet thickness
- Weight saving

Bodyshell material diagram of the steels used (coupé and cabrio)

Silver areas

The silver areas are soft deep-drawing steels of regular strength. In these areas all the usual welding methods can be used.

Red areas

The red areas consist of micro-alloyed high-strength steels. Resistance spot welding can easily be carried out in these areas.

However, metal active gas (MAG) welding is only permissible on approved areas. See the Workshop Information System (WIS) for further instructions and information.

Green area (cabrio only)

The green area consists of a particularly high-strength and torsionally stiff martensite phase steel.

This steel is only used in the cabrio for the window pillars of the A-pillars because particularly stringent demands are made on the strength of the vehicle at these points.

Body



Overview of bodyshell materials - smart fortwo coupé

P60.20-2063-00



Overview of bodyshell materials - smart fortwo cabrio

P60.20-2064-00

Crash management system (CMS)

CMS concept

Model series 451 features a bolt-on crash management system at the front and rear in the smart fortwo coupé and smart fortwo cabrio.

To prevent damage, the front CMS is mounted on the longitudinal frame member and the rear CMS on the frame-type integral support.

The CMS is a specially shaped steel profile that absorbs impact energy at a defined rate in the low vehicle speed range up to approx. 10 mph (16 km/h).

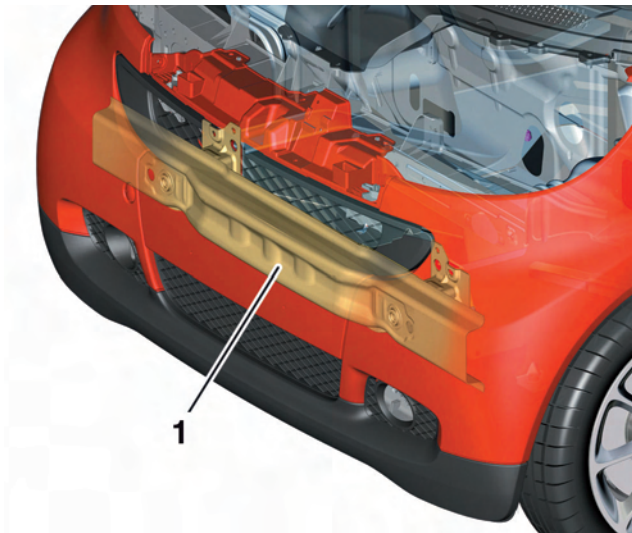

P62.30-2944-00

Front CMS

1 Front steel profile

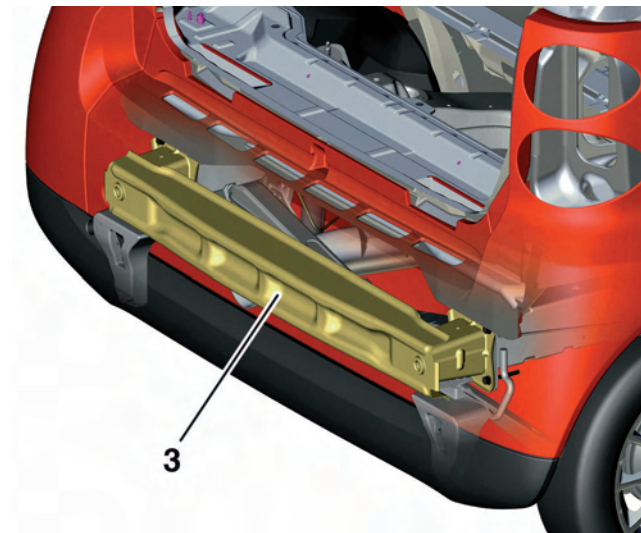

P64.20-4995-00

Rear CMS

3 Rear steel profile

smart accessories

i A complete overview of all accessory packages can be found:

- On the Internet at <http://pit.smart.com>

Accessory designation	Brief description	WIS no.	ASRA no.
Interior			
All-weather floor mats	To protect the standard carpeting.	—	G 68 9210 0
Velour floor mats	Optimum fit for the footwell on the driver and passenger side.	—	G 68 9210 0
Divider plus (including luggage compartment cover)	Luggage net with integral luggage compartment cover to allow the full volume of the luggage compartment to be used safely.	AZ68.50-P-0005MCC AZ68.50-P-0005MCO	G 68 9240 0
Telephone console	Plastic platform for MP3 player etc.	AZ82.70-P-0010MCU	G 82 8872 0
Rubber mats for the stowage compartments (set of 3)	For reducing the noise and preventing the slippage of small articles on the dashboard.	—	—
Smoking set	Package consisting of ashtray and cigarette lighter for the standard 12 V socket, clips easily in and out of the vertical strut.	—	G 68 5194 0
CD box (for 6 CDs)	Storage slots for up to 6 CDs, clips easily in and out of the vertical strut.	—	G68 4852 0
Luggage anchoring	For versatile anchoring of objects in the trunk.	—	—
Trunk net package	Package consisting of one net pocket for the left trunk side panel and one trunk floor net.	AZ68.50-P-0003MCC	G 68 7476 0

smart accessories

Accessories

Accessory designation	Brief description	WIS no.	ASRA no.
Eyeglass compartment	Flip-top plastic spectacle case with magnetic catch.	AZ68.10-P-0010MCC	G 68 4846 0
Luggage compartment cover (retractable cover with net pocket)	Retractable luggage compartment cover box with integral net pocket in the passenger compartment.	—	—
Cargo management system	Complete solution for clearly dividing the trunk with three different solutions: divider, fastening strap and shopping bag.		
Exterior			
smart design sticker	Decorative film with one or more digits in black or silver. The self-adhesive decorative film is car wash-proof, lightfast and can be applied horizontally or vertically with or without digits.	AZ72.10-P-0003MCC	G 72 7178 0
Bodypanel Fresh Up	Contains all CBS detachable parts installed on a smart fortwo in standard or metallic colors.	AR88.00-P-1200MCC	G 88 9991 0
Attaching parts for Bodypanel Fresh Up	Contains all attaching parts for all CBS detachable parts installed on the vehicle.	—	—
Chrome package	Radiator grille, outside mirror caps and rear trim strip plated in high gloss chrome.	—	—
Front fog lamps (chrome style)	The ideal supplement to the chrome package.	—	—

smart accessories

Accessory designation	Brief description	WIS no.	ASRA no.
Exterior			
Car cover	The portable garage for the smart fortwo made of hard-wearing, breathable and water-repellent material.	—	—
Function and electrical components			
Additional instruments (cockpit clock and tachometer)	Tachometer and cockpit clock, both with analog display and night illumination. Accent trim rings are available to match the interior color scheme.	AZ54.30-P-0001MCC	G 54 5073 0
Audio and telematics			
smart radio 9	Radio and CD player.	AZ82.60-P-0003MCC	G 82 7660 0
smart radio 10	Radio with integral 6-disk CD changer, MP3-compatible. The design differs from the smart radio 9 by its silver trim.	AZ82.60-P-0003MCC	G 82 7660 0
smart sound system	Consists of two tweeters and two midrange speakers.	AZ82.62-P-0002MCC	G 82 7970 0
Subwoofer	Active subwoofer, optimally tuned to suit the smart interior. It is mounted under the driver seat.	AZ82.62-P-0004MCU	G 82 7970 0 G 82 7814 0

smart accessories

Accessories

Accessory designation	Brief description	WIS no.	ASRA no.
Wheels and tires			
Light alloy wheel	Alurad Design 5 Front 155/60 R15 Rear 175/55 R15	AR40.10-P-1030MCU	G 40 1450 0 V40 2740 0
Safety			
First-aid pouch	Packed in a waterproof nylon pouch, with velcro fastener for attaching to the carpet.	—	—
Safety Plus package	2-piece foam insert for the stowage compartment in the liftgate with useful accessories such as a first-aid pouch, smart umbrella, flashlight and smart ice scraper.	—	—

Index

Numerics

5-speed automated manual
transmission 47

A

Acceleration skid control 73
Accessories 116
Active safety 17
Air conditioning 104
Alternator 21
Antilock brake system 73
ATA 99
Auto on/off headlamps 101
Autolight function 101
Automated manual
transmission control unit 57

B

Battery 20
Belt drive 38
Bleed cooling system 40
Body 114
Bodypanels 106
Bodyshell 113
Borg-Warner synchronization 54
Brake assist system 73
Brake pedal module 71

C

CBS 107
Central locking 96
Clutch motor 63
Coming-Home function 101
control unit 68
Coolant circuit 39
Crash management system 115
Customized Bodypanel System (CBS) 106

D

Data link connector 26
Diagnostic tester 26
Dimensions
smart fortwo cabrio 11
smart fortwo coupé 10
Door structure 86

E

Electric power steering 75
Electronic brake force distribution 73
Electronic selector lever
module control unit 58
Electronic Stability Program 73, 74
Emergency unlocking of
rear-end door 89
Engine braking regulation 73
Engine mount 41
Evaporative emission control system 42
Exhaust aftertreatment 45

F

Front axle 64
Fuel tank 42
Full roof 91

H

Heated seats 108
Heating 104

I

Injection control 35
Instrument cluster 21, 84, 85
Instrument panel 83
Interior design 82
Interior protection/
tow-away protection 99

L	
Leak test	42
M	
Maintenance concept	13
Maintenance interval display	14
Maintenance intervals	13
Maintenance points	
Engine compartment	16
Front end	15
Mechanical park pawl	61
Muffler system	45
Multifunction display	84
O	
Occupant restraint systems	18
Oil Service Plus	13
Overall network - CAN bus/LIN bus	23
P	
Paddle shifts on steering wheel	80
Paintwork	106
PANIC alarm	97
Panoramic sunroof	91
Parking brake	69
Passive safety	18
Power and torque graph	31
R	
Radio 10	102
Radio 9	102
TPM	68
Rear axle	65
Rear-end door	88
Recirculated air mode	105
Remote soft top opening	97
Remote trunk opening	97
Restraint system	109
S	
Safety concept	17, 18
SAM control unit	28
SCN (Software Calibration Number)	
coding	27
Seats	108
Service brake	69
Service flap	15
Shift mechanism	49
Side door emergency opening	86
Side doors	86
Single-plate dry clutch	62
Soft top control	94, 95
Soft top operation	93
Speakers	103
Starter	20
Start-off assist	73
Stretch belt	38
System	99
T	
TAN generator	27
Tire pressure sensing	67
Torque support	41
Transmission motors	56
Transmission mount	41
Transmission rpm sensor	55
tridion safety cell	113
Tritop fabric soft top	92
V	
Valve assembly	33
Vehicle characteristics	9
Vehicle concept	9
W	
Weight sensing system (WSS)	110
Wiring harness repair capability	25
Wiring harness repair kit	25